

**CROWN**

**WD 2300S**

Series



# Built for the task.



THE X10 HANDLE™

Crown's versatile WD 2300S Series offers an ideal lift truck for high density, stock-to-dock applications - combining the capability of a stacker, the flexibility of a pallet truck, and the capacity to transport or stack two 1000 kg pallets.

Both the mast and fork carriage designs have been optimised to provide maximum visibility and secure load handling. The forks can lift a 1000 kg load up to 2100 mm while the elevating outriggers carry an additional 1000 kg load (or 2000 kg with forks lowered). The elevating outriggers also provide increased ground clearance for traversing dock boards and slopes.

Crown's award winning X10™ handle brings all controls within fingertip reach. Tactile and visual differentiation enhances control recognition to further improve operator productivity.



A compact power unit provides a high degree of manoeuvrability in congested stockrooms and busy loading docks. The narrow overall width allows for easy block stacking and wall-to-wall loading of lorries and trailers.

An advanced SEM traction control system provides smooth acceleration, and regenerative braking. Travel speeds are nearly constant whether driving up or down an incline and regardless of loading. A ramp hold feature minimises the possibility of unintended reverse travel when brakes are released on an incline. Automatic load/height sensing regulates maximum travel speeds.

The fold-down platform with folding side restraints gives the operator the option of pedestrian operation in congested areas or ride-on operation for more intensive applications with longer travel distances.

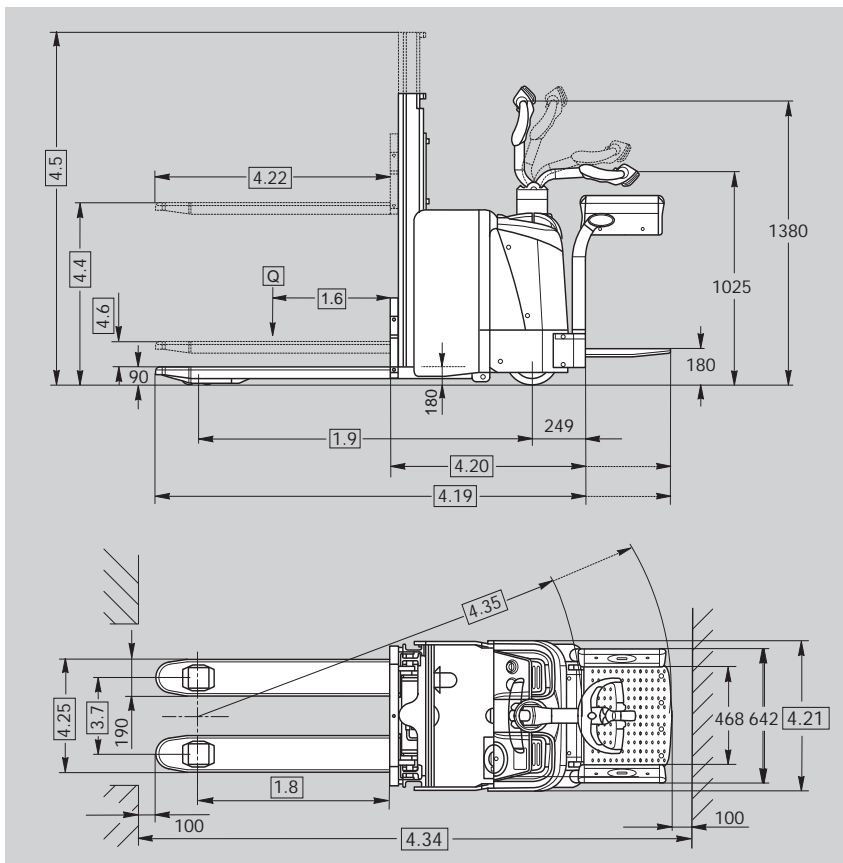

**Electrical System**

24 V electrical system with nominal battery capacity to 360 Ah.

**Standard Equipment**

1. SEM traction control
2. Rabbit/Turtle switch
3. Emergency disconnect
4. Key switch
5. Horn
6. Two-stage brake, spring applied, electro-magnetically released
7. Suspended floorboard
8. Cushioned side restraints
9. Vulkollan drive tyre, castor wheels and load wheels
10. Tandem load wheels
11. Auto reverse safety switch active in walkie mode
12. Combi instrument (hour meter, BDI with lift lock out)
13. Battery roll-out
14. SBE 160 red connector

**Optional Equipment**

1. Battery connector (DIN 160A)
2. Freezer conditioning
3. Diagnostic handset

**Safety Regulations**

Conforms to European safety standards. Dimensions and performance data given may vary due to manufacturing tolerances. Performance is based upon an average size vehicle and is affected by weight, condition of truck, how it is equipped and the conditions of the operating area. Crown products and specifications are subject to change without notice.

1.2	<b>Model</b>			WD 2300S
1.3	<b>Power</b>			electric
1.4	<b>Operator Type</b>			pedestrian / rider
1.5	<b>Load Capacity</b>	t		2.0
1.6	<b>Load Centre</b>	mm		600
1.8	<b>Load Distance</b>	lowered	mm	938
1.9	<b>Wheel Base</b>	lowered	mm	1654
2.1	<b>Weight</b>	less battery	kg	852 / 870
2.4	<b>Axle Load</b>	with load** front/rear	kg	1040 / 2114
2.5	<b>Axle Load</b>	w.o. load front/rear	kg	852 / 298
3.1	<b>Tyre Type</b>			Vulkollan
3.2	<b>Wheel Size</b>	front	mm	Ø 230 x 70
3.3	<b>Wheel Size</b>	rear	mm	Ø 82 x 82
3.4	<b>Additional Wheels</b>	castor wheels	mm	Ø 125 x 50
3.5	<b>Wheels</b>	no. (x=driven) front/rear		1x + 2/4
3.7	<b>Truck Width</b>	rear	mm	370
4.2	<b>Mast</b>	collapsed height	mm	1229 / 1429
4.4	<b>Lift Height</b>		mm	<b>1700 / 2100</b>
4.5	<b>Mast</b>	extended height	mm	2050 / 2450
4.6	<b>Initial Lift</b>		mm	130
4.15	<b>Fork Height</b>	lowered	mm	90
4.19	<b>Overall Length *</b>		mm	2105 / 2525
4.20	<b>Headlength *</b>		mm	955 / 1375
4.21	<b>Overall Width</b>		mm	712
4.22	<b>Fork Dimensions</b>		mm	190 x 60 x 1150
4.24	<b>Fork Carriage Width</b>		mm	670
4.25	<b>Width Across Forks</b>		mm	560
4.32	<b>Ground Clearance</b>	centre wheelbase	mm	32
4.34	<b>Working Aisle Width *</b>	800 x 1200 length	mm	2394 / 2788
4.35	<b>Turning Radius *</b>	lowered	mm	1916 / 2310
5.1	<b>Travel Speed *</b>	w./w.o. load	km/h	5.6 / 6 / 5.6 / 8.5
5.2	<b>Lift Speed</b>	w./w.o. load	m/s	0.11 / 0.18
5.3	<b>Lowering Speed</b>	w./w.o. load	m/s	0.2 / 0.2
5.7	<b>Max. Gradeability</b>	w./w.o. load	%	6 / 15
5.10	<b>Service Brake</b>			electromagnetic
6.1	<b>Traction Motor</b>	60 min. rating	kW	1.5
6.2	<b>Lift Motor</b>	10% ED	kW	2.2
6.3	<b>Max. Battery Box Size</b>		mm	284 x 624 x 627
6.4	<b>Battery Voltage</b>	nom. capacity 5h rating	V/Ah	24/300 (L) 360 (H)
6.5	<b>Battery Weight</b>	nominal +5%	kg	288
8.1	<b>Type of Controller</b>	drive		transistor

**Lift Height and Load**

	Lift control	Lift Height mm	Max. Load kg
<b>Load on Outriggers only</b>	Outrigger Lift	220	1000
<b>Load on Forks only</b>	Outrigger Lift	220	2000
	Mast Lift	1570	1000
	Mast Lift	2100 <sup>(1)</sup>	800
<b>Load on Outriggers &amp; Forks</b>	Outrigger Lift	220	1000
	Mast Lift	1570	1000
	Outrigger Lift	220	1000
	Mast Lift	1700 <sup>(2)</sup>	800

<sup>(1)</sup> Lift stops automatically at 1700 mm (release and press lift for additional lift height).

<sup>(2)</sup> Outriggers lower automatically above 1700 mm.

\* Platform in up position / Platform in down position

\*\* with 2000 kg load

Crown  
European Headquarters  
Moosacher Strasse 52  
80809 Munich  
Germany  
Tel +49(0)89-93002-0  
Fax +49(0)89-93002-133

German Locations:  
Hamburg  
Berlin  
Hanover  
Cologne  
Dortmund  
Frankfurt  
Stuttgart  
Nuremberg  
Munich

Crown Lift Trucks Ltd.  
Locations in United Kingdom:

Sunbury, Surrey TW16 7EF  
Tel +44(0)845-8509276  
Fax +44(0)845-8509277

Warrington, Cheshire WA2 8TS  
Tel +44(0)845-8509280  
Fax +44(0)845-8509281

Almondsbury, Bristol BS32 4RX  
Tel +44(0)845-8509268  
Fax +44(0)845-8509269

Swindon, Wiltshire SN3 4TS  
Tel +44(0)845-8509270  
Fax +44(0)845-8509271

Bellshill, Lanarkshire ML4 3LX  
Tel +44(0)845-8509265  
Fax +44(0)845-8509266

Crown Handling NV  
Satenrozen 12  
2550 Kontich  
Belgium  
Tel +32(0)3-4507171  
Fax +32(0)3-4507181

Crown Intern Transport BV  
Damsluisweg 75  
1332 EB Almere  
Netherlands  
Tel +31(0)36-5494180  
Fax +31(0)36-5494276



**PT. HASTA PUTERA PERKASA**  
**Roxy Mas Centre Blok C 3 / 12A**  
**Jl. KH. Hasyim Ashari, Jakarta 10150**  
**Phone. (021) 6330358, Fax. (021) 6327455**  
**E-mail Address : hppcrown@hastaputera.com**

[www.crown.com](http://www.crown.com)

Because Crown is continually improving its products, specifications are subject to change without notice.

Crown, the colour beige, the Momentum symbol, X10, The X10 Handle, the stylised X10 logo, Access 1 2 3<sup>®</sup>, InfoPoint and Work Assist are trademarks of Crown Equipment Corporation.

Copyright 2005 Crown Equipment Corporation  
WD 2300S BROCH GB 05/06, 30 – M01383-006-02  
Printed in Germany