

CROWN

# PR 4500 SERIES

## Specifications

Rider Pallet Truck



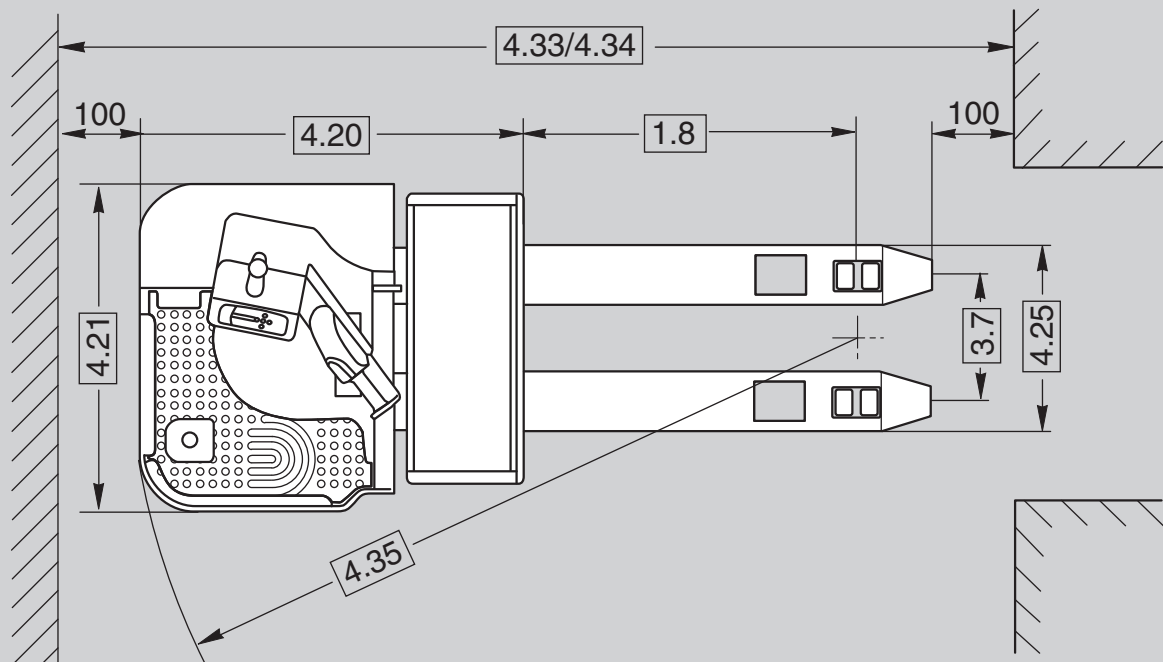
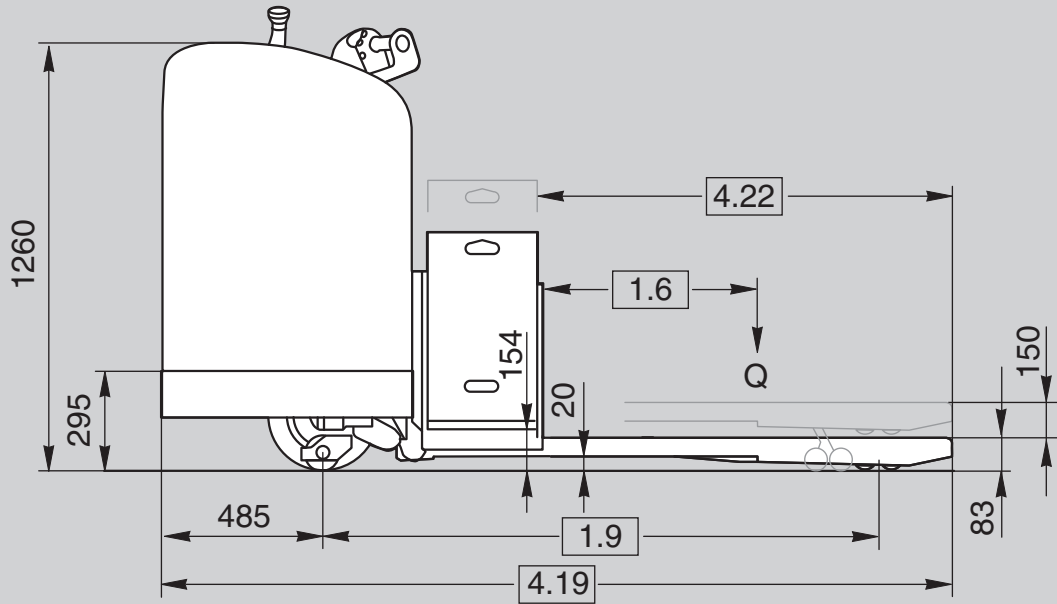

General Information	1.1	Manufacturer	Crown Equipment Corporation			
	1.2	Model				PR 4500-3.0
	1.3	Power				electric
	1.4	Operator Type				stand
	1.5	Load Capacity		Q	t	3.0
	1.6	Load Centre		c	mm	see table 1
	1.8	Load Distance		x	mm	see table 1
	1.9	Wheel Base		y	mm	see table 1
	Weights	2.1	Weight	less battery		kg
2.2		Axle Load	w. load, front / rear		kg	see table 1
2.3		Axle Load	w.o. load, front / rear		kg	see table 1
Tyres	3.1	Tyre Type				Polyurethane
	3.2	Wheel Size	front		mm	Ø 330 x 200
	3.3	Wheel Size	rear		mm	Ø 83 x 83
	3.4	Additional Wheels	castor wheels		mm	Ø 100 x 65
	3.5	Wheels	number (x=driven) front/rear			1x + 2/4
	3.6	Track Width	front	b10	mm	0
	3.7	Track Width	rear	b11	mm	280 / 380 / 505
Dimensions	4.4	Lift Height		h3	mm	150
	4.8	Operator Stand Height		h7	mm	295
	4.15	Fork Height	lowered	h13	mm	83
	4.19	Overall Length		l1	mm	see table 1
	4.20	Headlength		l2	mm	970   1135
	4.21	Overall Width		b1	mm	965
	4.22	Fork Dimension		thxwxl	mm	78 x 180 x see table 1
	4.25	Width Across Forks		b5	mm	460 / 560 / 685
	4.32	Ground Clearance	centre wheelbase, raised	m2	mm	184
	4.33	Working Aisle Width *	1000 x 1200 mm traverse, raised	Ast	mm	2315   2480
4.34	Working Aisle Width **	800 x 1200 mm length, raised	Ast	mm	2515   2680	
4.35	Turning Radius		Wa	mm	see table 1	
Performance	5.1	Travel Speed	w. / w.o. load		km/h	10.1 / 12.9 (10.1 / 14.5) ***
	5.2	Lift Speed	w. / w.o. load		m/s	0.04 / 0.06
	5.3	Lowering Speed	w. / w.o. load		m/s	0.09 / 0.06
	5.7	Gradeability	w. / w.o. load, 30 min. rating		%	5 / 15
	5.10	Service Brake				electric
Motors	6.1	Traction Motor	rating at S2 60 min.		kW	3.9
	6.2	Lift Motor	rating at S3 15%		kW	1.5
	6.3	Max. Battery Box Size		lxwxh	mm	169 x 874 x 803   335 x 790 x 803
	6.4	Battery Voltage	nominal capacity K5		V / Ah	24 / 310-324   24 / 465-756
	6.5	Battery Weight	min. / max.		kg	165 / 410   440 / 680
8.1	Type Controller	drive			AC traction	

					Battery Box Size								
					169 x 874 x 803 mm			335 x 790 x 803 mm					
1.6	Load Centre		c	mm	400	500	600	400	500	600	800	1000	1200
1.8	Load Distance ****	raised	x	mm	570	770	895	570	770	895	1370	1770	2095
1.9	Wheel Base ****	raised	y	mm	1055	1255	1380	1220	1420	1545	2020	2420	2745
2.1	Weight	less battery		kg	771	780	785	816	825	831	896	915	930
2.2	Axle Load	with load	front	kg	1685	1689	1691	1798	1802	1804	1373	1379	1383
		with load	rear	kg	2528	2533	2536	2698	2703	2707	3203	3217	3227
2.3	Axle Load	w.o. load	front	kg	970	978	982	1197	1204	1209	1182	1196	1208
		w.o. load	rear	kg	243	244	245	299	301	302	394	399	403
4.19	Overall Length		h4	mm	1765	1965	2085	1930	2130	2250	2730	3130	3450
4.22	Fork Length		l	mm	795	995	1120	795	995	1120	1595	1995	2320
4.35	Turning Radius ****	raised	Wa	mm	1690	1885	2010	1855	2050	2175	2645	3040	3365

\* Fork length 1000 mm

\*\* Fork length 1200 mm

\*\*\* Speed with optional productivity package

\*\*\*\* Forks lowered + 115 mm

**Standard Equipment**

- 24-volt electrical system
- Access 1 2 3® Comprehensive System Control
- Access 1 2 3 Display (includes BDI with lift lockout, hour meters, event codes, PIN code access and three performance levels)
- e-Gen™ braking system with automatic parking brake
- Crown manufactured AC traction motor
- Operator driveability features
  - Spacious variable side-stance compartment
  - Suspended floorboard
  - Premium platform cushion
  - Large entry/exit opening
  - Power Steering
  - Profiled, padded backrest
  - Padded knee cushion
  - Urethane covered control handles with tactile feedback
  - Entry bar safety switch
- Tandem polyurethane load wheels
- Heavy-duty articulating shim-free casters
- InfoPoint™ System
- SBE 160 red battery connector
- Colour-coded wiring
- Steel power unit doors
- Key switch
- Horn
- Pallet entry rollers
- Drive tyre black polyurethane
- Forward steering

**Optional Equipment**

- Productivity package
- 1220, 1525 or 1830 mm high load backrest (hinged, lift-off or bolt-on)
- Quick adjustment caster
- Quick adjustment caster with torsion bar
- Battery retainer interlock switch
- Battery compartment rollers
- Work Assist™ Accessories:
  - Accessory tube
  - Strobe light
  - Flashing light
  - Work lights
  - Storage pouch
  - Clip pad and hook
  - Shrink wrap tray
  - Accessory clamp
  - Accessory mounting plate
- Storage module
- Drive tyre options
- Freezer condition and corrosion protection

- Special paint
- Skid adaptor
- Audible travel alarm
- Reverse steering
- Power source for accessories

**Operator Area and Controls**

The PR 4500 Series incorporates numerous design features to improve operator comfort and productivity. The side-stance position provides the operator with maximum visibility. The compartment cradles the operator with a wrap-around chassis while the suspended floorboard with premium floor mat provides maximum comfort. The PR has a left hand steer tiller with full-time power steering. Full function control is provided for the right hand to control travel direction and speed, raise, lower and horn.

**Electrical System**

Heavy-duty 24-volt electrical system for demanding warehouse, dock and transport applications. Crown-manufactured AC drive motor is application designed for reliability and ease of service.

**Access 1 2 3® Comprehensive System Control with AC Traction**

This system provides unmatched truck control and system performance in:

- Traction control
- Operator interface
- Diagnostics

Crown's technology provides a closed-loop traction control system which maintains speed throughout the battery charge.

The large Crown-manufactured AC traction motor specifically designed for lift truck applications, provides improved acceleration and plug reversal contributing to greater productivity. The Access display offers seven hour meter readouts and odometer. The operator message mode includes BDI, truck hours, odometer, trip odometer, or timer. Built-in PIN-code (up to 25) capability that can be programmed by customers.

The Access display also includes a full featured on-board service tool. The service engineers can actively

view inputs and outputs during truck operation. Event code history including the last 16 event codes is accessible. No service key, laptop, or handset required.

**InfoPoint™**

InfoPoint System allows your engineers to troubleshoot without complicated schematics, wiring diagrams or cumbersome service manuals for over 95% of your repairs. Simplicity is complete with colour-coded component maps located on the truck.

**Hydraulics**

A heavy-duty pump, motor, reservoir and control are assembled into one unit. A centrally located lift cylinder, mounted vertically, is equipped with long-life polyurethane packing. A pressure compensating flow control valve is an integral part of the valve block and regulates maximum lowering speed. Overload valve protects hydraulic components.

**Drive Unit**

Crown-manufactured gears are hard finished and dual machined for high quality. Gear train runs in an oil-filled, sealed housing. Drive tyre axle is mounted in the drive unit on both sides for maximum strength in rough floor or docking applications. Drive unit is top and bottom mounted. Top mount is a large, tapered roller bearing for vertical or horizontal forces. Bottom mount has four shock mounted rollers on drive unit running in a hardened steel roller race.

**Caster System**

Standard on the PR 4500 Series are shim-free, spring loaded, stabilising casters. Quick adjustment casters or quick adjustment casters with torsion bar are optional. Quick adjustment casters enable braking, traction, steer effort and stability to become balanced. This system can also increase tyre life by as much as 60 percent by permitting more tyre wear. The torsion bar suspension is designed to maximise stability on tall unwieldy and less stable loads.

**Fork Assembly**

To facilitate pallet entry/exit Crown has engineered several features into their fork assembly. Standard-tip forks have pallet entry rollers to lift fork over bottom board of pallet. Abrasion resistant steel entry/exit slides on both sides of each fork have convex bottom surfaces to prevent snagging as forks move over bottom boards of pallet. Exit roller design prevents load wheel from dropping after crossing bottom board. Fork adjustability is done at the toe with no need to remove a cover plate. Fork heel height adjustment is done quickly without removing battery.

**Power Unit Structure**

Heavy gauge steel is used in the platform and power unit skirt with additional steel reinforcement where needed. The power unit door and motor cover also utilise heavy steel for protection of critical components and long term durability. The power unit door swings out for easy access to components.

**e-GEN™ Braking System**

Variable regenerative motor braking is optimised and virtually eliminates brake maintenance. The closed-loop Access 1 2 3 traction control will keep the truck static until a travel input is requested, even when operating on a grade. Automatic electric parking brake activates when the operator releases the brake pedal and the truck has been stationary for four seconds, the truck is keyed off, or the battery has been disconnected.

**Safety Regulations**

Conforms to European safety standards. Dimensions and performance data given may vary due to manufacturing tolerances. Performance is based on an average size vehicle and is affected by weight, condition of truck, how it is equipped and the conditions of the operating area. Crown products and specifications are subject to change without notice.

PT. HASTA PUTERA PERKASA

Roxy Mas Centre Blok C 3 / 12A

Jl. KH. Hasyim Ashari, Jakarta 10150

Phone. (021) 6330358, Fax. (021) 6327455

E-mail Address : hppcrown@hastaputera.com



European Manufacturing:

Crown Gabelstapler GmbH & Co. KG  
Roding, Germany  
www.crown.com