

Technical specifications

| | | |
|------------------------|----------------------|----------------|
| Capacity | | 2300 kg |
| Headlength | L₂ | 360 mm |
| Fork width | b | 160 mm |
| Lift | h₃ | 127 mm |
| Lowered fork height | S | 75 mm |
| Lowered fork clearance | F | 30 mm |
| Steer wheels | | ø 180 x 50 mm |
| Load wheels | | ø 74 x 98 mm |

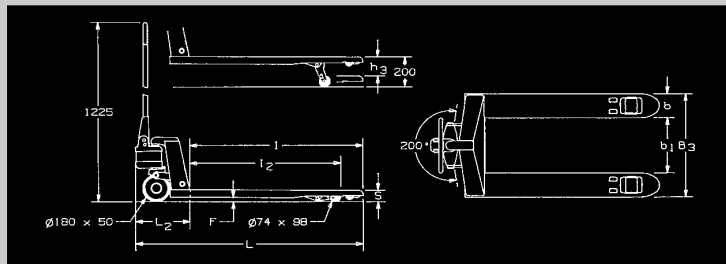

| Model | PTH 18-32 | PTH 18-39 | PTH 18-45 | PTH 20-32 | PTH 20-39 | PTH 20-45 | PTH 27-32 | PTH 27-39 | PTH 27-45 |
|---------------------|-----------------------------|-----------|-----------|-----------|-----------|-----------|-----------|-----------|-----------|
| Overall length | L 1155 mm | 1350 mm | 1510 mm | 1155 mm | 1350 mm | 1510 mm | 1155 mm | 1350 mm | 1510 mm |
| Fork length | l 795 mm | 990 mm | 1150 mm | 795 mm | 990 mm | 1150 mm | 795 mm | 990 mm | 1150 mm |
| Load wheel lowered | l₂ 648 mm | 843 mm | 1003 mm | 648 mm | 843 mm | 1003 mm | 648 mm | 843 mm | 1003 mm |
| Outside fork spread | B₃ 450 mm | 450 mm | 450 mm | 520 mm | 520 mm | 520 mm | 685 mm | 685 mm | 685 mm |
| Inside fork spread | b₁ 130 mm | 130 mm | 130 mm | 200 mm | 200 mm | 200 mm | 365 mm | 365 mm | 365 mm |
| Truck weight | 55 kg | 60 kg | 64 kg | 57 kg | 62 kg | 66 kg | 61 kg | 66 kg | 70 kg |

Other options: handbrake, skid adaptor, load backrest, quicklift, overload valve, wet application, galvanized.

| | | |
|---------------------------------|--------------------------------|-----------------|
| Model | | PTH 50 S |
| Capacity | | 1000 kg |
| Lowered fork height | | 85 mm |
| Raised fork height | | 800 mm |
| Outside fork spread | | 540 mm |
| Fork length | | 1150 mm |
| Headlength | L₂ | 440 mm |
| Steer wheels | Poly | ø 180 x 50 mm |
| Load wheels | Poly | ø 74 x 75 mm |
| Overload valve | | yes |
| Quicklift | | yes |
| Pumping strokes to full height: | if payload less than 120 kg | 27 |
| Pumping strokes to full height: | if payload greater than 120 kg | 66 |
| Truck weight | | 158 kg |
| Steer angle | | 200 ° |

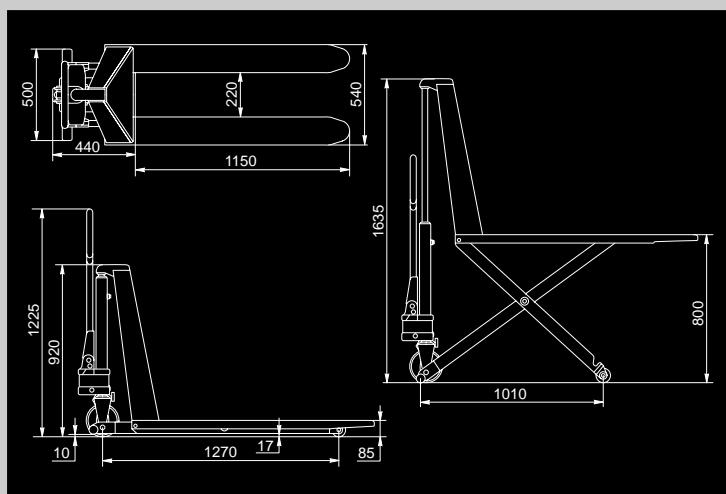

PT. HASTA PUTERA PERKASA

Roxy Mas Centre Blok C 3 / 12A
 Jl. KH. Hasyim Ashari, Jakarta 10150
 Phone. (021) 6330358, Fax. (021) 6327455
 CROWN E-mail Address : hppcrown@hastaputera.com

