

CROWN

WP 3000 SERIES

Specifications

Pedestrian Pallet Truck with High Lift



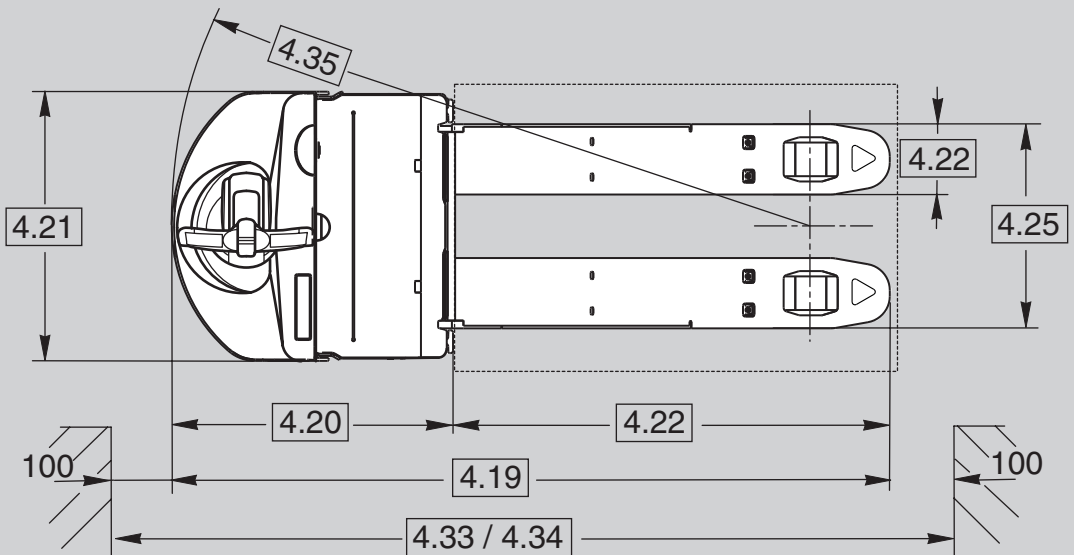
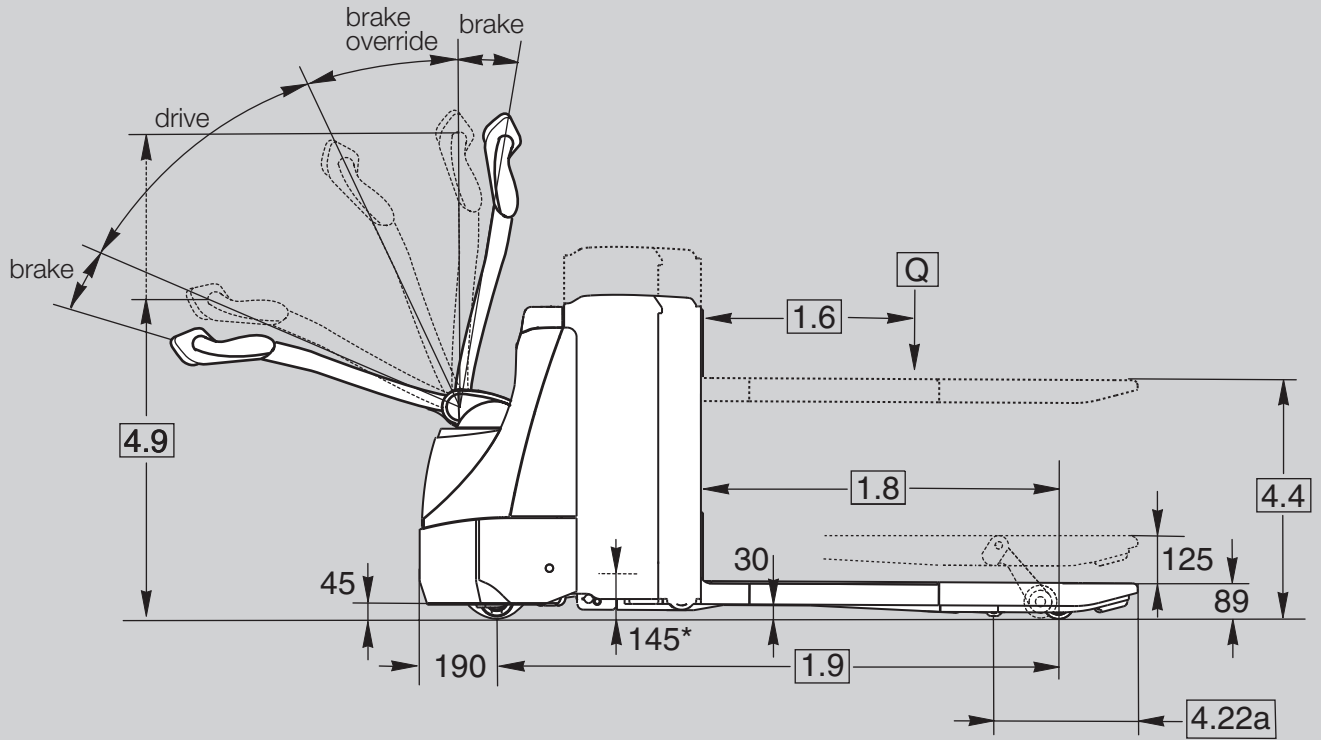

* battery roll out height

General Information	1.1	Manufacturer	Crown Equipment Corporation				
	1.2	Model	WP 3080-2.0				
	1.3	Power	electric				
	1.4	Operator Type	pedestrian				
	1.5	Load Capacity	pallet truck	Q	t	2.0	
			stacker	Q	kg	800	
	1.6	Load Centre		c	mm	600	
	1.8	Load Distance	outriggers raised / lowered	x	mm	900 / 940	
1.9	Wheel Base	outriggers raised / lowered	y	mm	1343 / 1399 1443 / 1499		
Weights	2.1	Weight	less battery		kg	490 535	
	2.2	Axle Load	w. load front / rear		kg	947 / 1696 (968/1702) 982 / 1765	
			w.o. load front / rear		kg	495 / 148 (516/154) 562 / 185	
Tyres	3.1	Tyre Type				Vulkollan	
	3.2	Wheel Size	front		mm	Ø 250 x 85	
			rear		mm	Ø 82 x 110	
	3.4	Additional Wheels	castor wheels		mm	Ø 90 x 50	
	3.5	Wheels	no. (x=driven) front/rear			1x + 2/2	
	3.6	Track Width	front	b ₁₀	mm	478	
			rear	b ₁₁	mm	370	
Dimensions	4.3	Free Lift		h ₂	mm	536	
	4.4	Lift Height		h ₂ + h ₁₃ + h ₅	mm	750	
	4.6	Initial Lift		h ₅	mm	125	
	4.9	Tiller Arm Height	in drive position min./max.	h ₁₄	mm	780 / 1197	
	4.15	Fork Height	lowered	h ₁₃	mm	89	
	4.19	Overall Length ^{2 3}	outriggers lowered	l ₁	mm	1799 1899	
	4.20	Headlength	outriggers raised / lowered	l ₂	mm	665 / 649 765 / 749	
	4.21	Overall Width		b ₁	mm	712	
	4.22	Fork Dimension		thxwxl	mm	60 x 186 x 1150	
	4.22a	Fork Tip Length ³			mm	393	
	4.25	Width Across Forks		b ₅	mm	540	
	4.32	Ground Clearance	centre wheelbase	m ₂	mm	30	
	4.34	Working Aisle Width [*]	pallet 800x1200 length, outriggers raised / lowered	Ast	mm	2034 / 2050 2134 / 2150	
4.35	Turning Radius ¹	outriggers raised	Wa	mm	1534 1634		
Performance	5.1	Travel Speed	w./w.o. load		km/h	6.0 / 6.0	
	5.2	Lift Speed	w./w.o. load		m/s	0.11 / 0.17	
	5.3	Lowering Speed	w./w.o. load		m/s	0.15 / 0.13	
	5.8	Max. Gradeability	w./w.o. load 5 min. rating		%	10 / 25	
	5.10	Service Brake				electric	
Motors	6.1	Traction Motor	rating at S2 60 min.		kW	1.5	
	6.2	Lift Motor	rating at S3 15 %		kW	1.3	
	6.3	Battery	acc. to DIN 43535			no, A	B
		Max. Battery Box Size		lxwxh	mm	146 x 660 x 591 (683) 212 x 624 x 627	
	6.4	Battery Voltage	nominal capacity K5		V/Ah	24 / 150 (200) 24 / 250	
	6.5	Battery Weight			kg	153 (180) 212	
8.1	Type of Controller	drive			transistor		

¹ outriggers lowered +56 mm

² outriggers raised +16 mm

³ 1200 mm fork length +50 mm

* Ast calculation applies to 1150 mm and 1200 mm fork length

with optional 200 Ah battery compartment use values in brackets

Standard Equipment

1. X10® control handle places all truck functions at the operator's fingertips
2. 24-Volt fused electrical system
3. e-GEN™ Braking System offers regenerative and frictionless electric braking
4. Electric parking brake
5. Maintenance free 3-phase (AC) traction motor
6. 150 Ah lift-out battery compartment
7. Rabbit/turtle switch incorporates two levels of programmable travel performance
8. Brake override zone, travel possible in upper brake zone at creep speed
9. Key switch
10. Horn button in each handgrip
11. Battery connector SBE 160 red
12. Emergency disconnect
13. Vulkollan drive tyre and single load wheels
14. Castor wheels connected with torsion bar
15. Auto reverse safety switch
16. Battery discharge indicator with lift lock out and integrated hourmeter and fault code readout
17. Ramp hold
18. Steel battery top cover
19. Fork tip indicators

Optional Equipment

1. Auxiliary fork lift switches on battery cover
2. 200 Ah lift-out battery compartment
3. 250 Ah roll-out battery compartment (right hand side, forks first direction)
4. Battery connector DIN 160 A
5. Freezer conditioning -30°C operating temperature
6. 1200 mm fork length
7. Drive wheel rubber Ø 250 x 100 mm
8. Drive wheel Supertrac Ø 250 x 85 mm
9. Tandem load wheels Ø 82 x 82 mm, Vulkollan
10. Sealed high frequency on-board charger
11. Keypad
12. InfoLink® Ready
13. 970 mm high load backrest
14. Special paint
15. Welded fork marks
16. Low skirt clearance 33 mm

17. Outrigger lift/lower switches on left and right side of X10 Control Handle

Operator Controls

The high-lift fork design provides postural relief for operators who manually transfer goods from pallet to shelf. The forks are positioned such that the top of the load is at a comfortable working height. As layers of goods are removed, the forks are raised to keep the working height constant. Optional lift buttons located on top of the battery cover enable operators to easily raise the load while standing adjacent to the pallet.

The WP's robust X10® control handle is designed to allow for an optimum turning radius with low steer effort. All control buttons can be operated with either hand and can be accessed with minimum hand and wrist movement. The horn buttons are integrated in the hand grips. An ergonomic forward/reverse thumb wheel allows for precise manoeuvring.

A rabbit/turtle switch allows operators to select the maximum travel speed in order to match the operating conditions. The e-GEN braking system is activated when the forward/reverse thumb wheel is returned to neutral, during plugging or whenever the tiller is positioned in the upper or lower braking position. Brake rate is adjustable with handset.

Frame & Chassis

The optimised steel structure results in a rugged design which has minimum deflection and low stresses. A removable steel cover ensures internal components are protected against impacts yet easily accessible for service. The 8 mm thick steel skirt and the round contour gives the truck maximum protection and avoids damaging goods.

The forks with pull rod linkage are manufactured from a high tensile strength steel and feature an integrated exit and entry ramp for safe and easy pallet handling.

Twin, hard-chromed initial lift cylinders and a torsion bar provide improved load stability.

The Vulkollan load wheels incorporate a debris cover to protect the bearing.

Electrical System and e-GEN™ Braking

A heavy-duty 24-volt fused electrical system provides optimum travel and lift speeds. The transistor control is sealed from dirt, dust and moisture for trouble-free operation. An on-board diagnostic system reduces troubleshooting times to a minimum. An optional handset allows various performance levels to be tailored to the requirements of the customer and application. The e-GEN braking system utilises the controller and AC motor to deliver the optimum level of braking based on inputs. The power of the high-torque AC traction motor is used to stop the truck and keep it static until a travel input is requested, even when operating on a gradient.

Gearbox, Traction Motor and Brake

The heavy duty gearbox is designed for minimum noise. A rugged helical gear set delivers trouble free operation and long life. The transistor control module works in conjunction with the AC drive motor to provide responsive acceleration and precise control. The excellent acceleration enhances efficient pallet entry and exit to increase productivity. The parking brake mounted directly on the traction motor is spring applied and electro-magnetically released. The park brake is only activated when the thumb wheel is returned to neutral and no tyre movement is sensed, so rotor and disc life is extended. Park brake components are easily accessed for inspection and replacement.

Battery and Charger

The battery as well as the connector is easily accessible. The battery lid can be easily opened or if necessary removed by simply undoing a latch. A built-in 30 amp sealed charger is available as an option. This premium solid-state charger is durable and efficient.

The sealed unit eliminates problems or failures related to contamination or moisture. It has an advanced memory feature to allow for opportunity charging. The charger can be set for either maintenance-free or industrial batteries.

Hydraulic Lift System

Heavy-duty hydraulic motor with integral pump and reservoir for maximum efficiency and durability. The flow control valve allows for smooth lowering even when the truck is fully loaded. A relief valve protects the components and chassis from overloading. The lift limit switch avoids unnecessary energy consumption, reduces noise emissions and prevents the lift linkage from undue stress. The smooth low noise hydraulic system makes the truck ideal for retail shop operation. Load wheel risers are made from high quality steel for maximum load capability. All bolts are plated to provide protection against rust and corrosion.

Brake Override Function

For easy operation in tight areas a brake override function is incorporated which allows the WP 3000 Series to be driven safely and precisely at creep speed with the handle in a near vertical position. The control handle remains within the profile of the power unit at all times, even when performing 90° turn.

Safety Regulations

Conforms to European safety standards. Dimensions and performance data given may vary due to manufacturing tolerances. Performance is based on an average size vehicle and is affected by weight, condition of truck, how it is equipped and the conditions of the operating area. Crown products and specifications are subject to change without notice.

