

CROWN

WP 3000 SERIES

Specifications

Pedestrian Pallet Truck



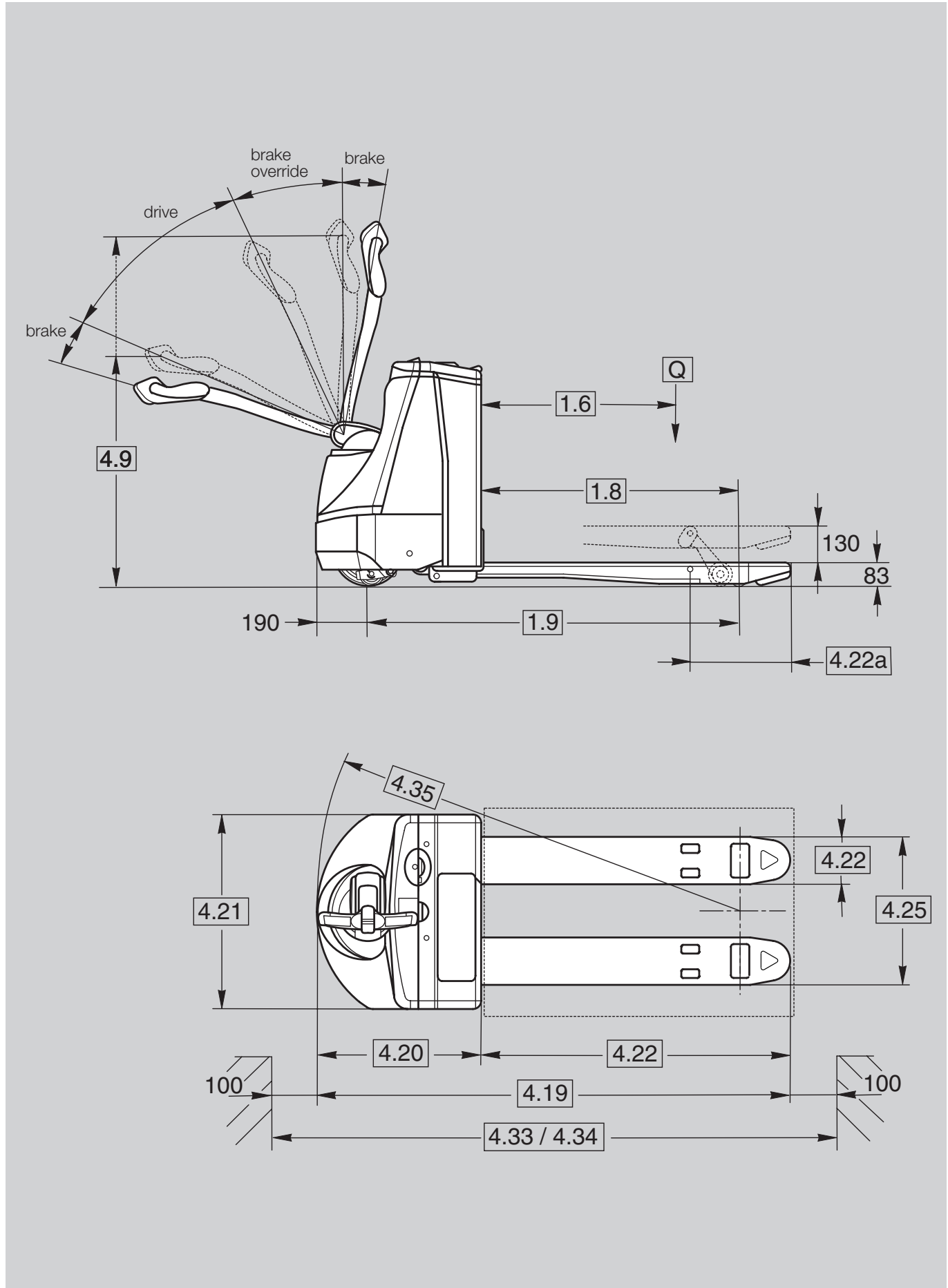

General Information	1.1	Manufacturer	Crown Equipment Corporation															
	1.2	Model											WP 3015-1.6	WP 3020-2.0				
	1.3	Power	electric															
	1.4	Operator Type	pedestrian															
	1.5	Load Capacity		Q	t									1.6	2.0			
	1.6	Load Centre		c	mm	see table 1												
	1.8	Load Distance	raised	x	mm	see table 1												
	1.9	Wheel Base	raised	y	mm	see table 1												
	Weights	2.1	Weight	less battery														see table 1
2.2		Axle Load	w. load front/rear														see table 1	
2.3			w.o. load front/rear														see table 1	
Tyres	3.1	Tyre Type	Vulkollan															
	3.2	Wheel Size	front														Ø 250 x 85	
	3.3		rear														Ø 82 x 110	
	3.4	Additional Wheels	castor wheels														Ø 90 x 50	
	3.5	Wheels	no. (x=driven) front/rear														1x + 2/2	
	3.6	Track Width	front		b10	mm	476											
	3.7		rear		b11	mm	350 / 370 / 500											
Dimensions	4.4	Lift Height		h3	mm	130												
	4.9	Tiller Arm Height	in drive position min./max.		h14	mm	780 / 1197											
	4.15	Fork Height	lowered		h13	mm	83											
	4.19	Overall Length		l1	mm	see table 1												
	4.20	Headlength ^{3 4 5 6}	lowered		l2	mm	546										611	
	4.21	Overall Width		b1	mm	712												
	4.22	Fork Dimension		thxwxl	mm	77 x 170 x 1150												
	4.22a	Fork Tip Length			mm	368												
	4.25	Width Across Forks		b5	mm	520 / 540 / 670												
	4.32	Ground Clearance	centre wheelbase		m2	mm	35											
	4.33	Working Aisle Width ^{** 4 5 6}	pallet 1000x1200 traverse, raised		Ast	mm	1744										1809	
4.34	Working Aisle Width ^{** 4 5 6}	pallet 800x1200 length, raised		Ast	mm	1944										2009		
4.35	Turning Radius	raised		Wa	mm	see table 1												
Performance	5.1	Travel Speed	w./w.o. load			km/h	6.0 / 6.0											
	5.2	Lift Speed	w./w.o. load			m/s	0.04 / 0.06											
	5.3	Lowering Speed	w./w.o. load			m/s	0.06 / 0.06											
	5.8	Max. Gradeability	w./w.o. load 5 min. rating			%	10 / 25											
	5.10	Service Brake					electric											
Motors	6.1	Traction Motor	rating at S2 60 min.			kW	1.5											
	6.2	Lift Motor	rating at S3 15 %			kW	1.3											
	6.3	Max. Battery Box Size		lxwxh	mm	146 x 660 x 604 ¹⁰ (212 x 624 x 627) ¹¹				212 x 624 x 627 ¹¹ (284 x 624 x 627) ¹¹								
	6.4	Battery Voltage	nominal capacity K5			V/Ah	24 / 150 (250)				24 / 250 (375)							
	6.5	Battery Weight			kg	153 (212)				212 (309)								
8.1	Type of Controller	drive				transistor												

Table 1				WP 3015-1.6				WP 3020-2.0											
1.6	Load Centre	c	mm	400	500	600	600	400	500	600	600	700	800	800	900	1000	1200		
1.8	Load Distance ¹	raised	x	mm	544	744	894	944	544	744	894	944	1144	1244	1344	1544	1744	2144	
1.9	Wheel Base ^{2 4 5 6}	raised	y	mm	900	1100	1250	1300	965	1165	1315	1365	1565	1665	1765	1965	2165	2565	
2.1	Weight ⁹	less battery		kg	315	320	323	325	315	320	323	325	334	349	354	366	383	407	
2.2	Axle Load ⁹	w. load	front	kg	562	606	670	670	725	788	829	881	955	959	1020	1069	1030	940	
			rear	kg	1506	1467	1406	1408	1802	1744	1706	1656	1591	1597	1546	1509	1395	1209	
2.3	Axle Load ⁹	w.o. load	front	kg	331	344	356	358	394	409	417	421	436	444	454	467	483	504	
			rear	kg	127	119	110	110	133	123	118	116	110	112	112	111	112	115	
4.19	Overall Length ^{3 4 5 6}	lowered	l1	mm	1346	1546	1696	1746	1411	1611	1761	1811	2011	2111	2211	2411	2611	3011	
4.22	Fork Length		l	mm	800	1000	1150	1200	800	1000	1150	1200	1400	1500	1600	1800	2000⁷	2400⁸	
4.35	Turning Radius ^{2 4 5 6}	raised	Wa	mm	1088	1288	1438	1488	1153	1353	1503	1553	1753	1853	1953	2153	2353	2753	

¹ Forks lowered +56 mm

² Forks lowered +72 mm

³ Forks raised +16 mm

⁴ with optional battery roll out +32 mm

⁵ with optional load backrest +50 mm

⁶ add 65 mm for 250 Ah compartment at WP 3015,

add 75 mm for 375 Ah compartment at WP 3020

⁷ Capacity derated to 1830 kg

⁸ Capacity derated to 1500 kg

⁹ all weights apply to small battery compartments

¹⁰ Layout A, cell type acc. to BS

¹¹ Layout B, cell type acc. to DIN 43535

* Ast calculation based on 1000 mm forks

** Ast calculation based on 1150 mm forks

with optional larger battery compartments use values in brackets

Standard Equipment

1. X10® control handle places all truck functions at the operator's fingertips
2. 24-Volt fused electrical system
3. e-GEN™ Braking System offers regenerative and frictionless electric braking
4. Electric parking brake
5. Maintenance free 3-phase (AC) traction motor
6. 150 Ah battery compartment (WP 3015); 250 Ah battery compartment (WP 3020)
7. Rabbit/turtle switch incorporates two levels of programmable travel performance
8. Brake override zone, travel possible in upper brake zone at creep speed
9. Key switch
10. Horn button in each handgrip
11. Battery connector SBE 160 red
12. Emergency disconnect
13. Vulkollan drive tyre and single load wheels
14. Spring loaded Polyurethane castor wheels
15. Auto reverse safety switch
16. Battery discharge indicator with lift lock out and integrated hourmeter and fault code readout
17. Ramp hold
18. Steel battery top cover
19. Fork tip indicators

Optional Equipment

1. 250 Ah battery compartment (WP 3015); 375 Ah battery compartment (WP 3020)
2. Battery connector DIN 160 A
3. Freezer conditioning -30°C operating temperature
4. Fork length and spread options
5. Battery roll out function to both sides (250 Ah and 375 Ah compartment only, increases headlength by 32 mm; not with load back rest)
6. Drive wheel rubber or sipped rubber Ø 250 x 100 mm
7. Drive wheel Supertrac Ø 250 x 85 mm
8. Tandem load wheels Ø 82 x 82 mm, Vulkollan

9. Sealed high frequency on-board charger (150 Ah and 250 Ah compartments only)
10. Keypad
11. InfoLink® Ready
12. Load back rest (lift out only, increases headlength by 50 mm)
13. Special paint
14. Welded fork marks

Frame & Chassis

The optimised steel structure results in a rugged design which has minimum deflection and low stresses. A removable steel cover ensures internal components are protected against impacts yet easily accessible for service. The 8 mm thick steel skirt and the round contour gives the truck maximum protection and avoids damaging goods. The forks with pull rod linkage are manufactured from a high tensile strength steel and feature an integrated exit and entry ramp for safe and easy pallet handling.

Wheels and Tyres

The adjustable polymer dampers of the castors give the drive wheel excellent grip and provide the truck with optimum stability. The Vulkollan load wheels incorporate a debris cover to protect the bearing.

Electrical System and e-GEN™ Braking

A heavy-duty 24-volt fused electrical system provides optimum travel and lift speeds. The transistor control is sealed from dirt, dust and moisture for trouble-free operation. An on-board diagnostic system reduces troubleshooting times to a minimum. An optional handset allows various performance levels to be tailored to the requirements of the customer and application. The e-GEN braking system utilises the controller and AC motor to deliver the optimum level of braking based on inputs. The power of the high-torque AC traction motor is used to stop the truck and keep it static until a travel input is requested, even when operating on a gradient.

Gearbox, Traction Motor and Brake

The heavy duty gearbox is designed for minimum noise. A rugged helical gear set delivers trouble free operation and long life. The transistor control module works in conjunction with the AC drive motor to provide responsive acceleration and precise control. The excellent acceleration enhances efficient pallet entry and exit to increase productivity. The parking brake mounted directly on the traction motor is spring applied and electro-magnetically released. The park brake is only activated when the thumb wheel is returned to neutral and no tire movement is sensed, so rotor and disc life is extended. Park brake components are easily accessed for inspection and replacement.

Battery and Charger

The battery is safely located in a fully enclosed battery compartment. The battery as well as the connector is easily accessible. The battery lid can be easily opened or if necessary removed by simply undoing a latch. A built-in 30 amp sealed charger is available as an option. This premium solid-state charger is durable and efficient. The sealed unit eliminates problems or failures related to contamination or moisture. It has an advanced memory feature to allow for opportunity charging. The charger can be set for either maintenance-free or industrial batteries.

Hydraulic Lift System

Heavy-duty hydraulic motor with integral pump and reservoir for maximum efficiency and durability. Twin, hard-chromed lift cylinders and a torsion bar provide improved load stability. The flow control valve allows for smooth lowering even when the truck is fully loaded. A relief valve protects the components and chassis from overloading. The lift limit switch avoids unnecessary energy consumption, reduces noise emissions and prevents the lift linkage from undue stress.

Thick wall bushings and grease fittings for all pivot points in the lift system make the truck ideal for heavy-duty industrial applications. Load wheel risers are made from high quality steel for maximum load capability. All bolts are plated to provide protection against rust and corrosion.

Operator Controls

The WP's robust X10® control handle is designed to allow for an optimum turning radius with low steer effort. All control buttons can be operated with either hand and can be accessed with minimum hand and wrist movement. The horn buttons are integrated in the hand grips. An ergonomic forward/reverse thumb wheel allows for precise manoeuvring. A rabbit/turtle switch allows operators to select the maximum travel speed in order to match the operating conditions. The e-GEN braking system is activated when the forward/reverse thumb wheel is returned to neutral, during plugging or whenever the tiller is positioned in the upper or lower braking position. Brake rate is adjustable with handset.

Brake Override Function

For easy operation in tight areas a brake override function is incorporated which allows the WP 3000 Series to be driven safely and precisely at creep speed with the handle in a near vertical position. The control handle remains within the profile of the power unit at all times, even when performing 90° turn.

Safety Regulations

Conforms to European safety standards. Dimensions and performance data given may vary due to manufacturing tolerances. Performance is based on an average size vehicle and is affected by weight, condition of truck, how it is equipped and the conditions of the operating area. Crown products and specifications are subject to change without notice.

European Manufacturing:
Crown Gabelstapler GmbH & Co. KG
Roding, Germany
www.crown.com

