

CROWN

Specifications

RC 5500 Series

Stand-up Rider
Lift Truck

RC 5500

Series



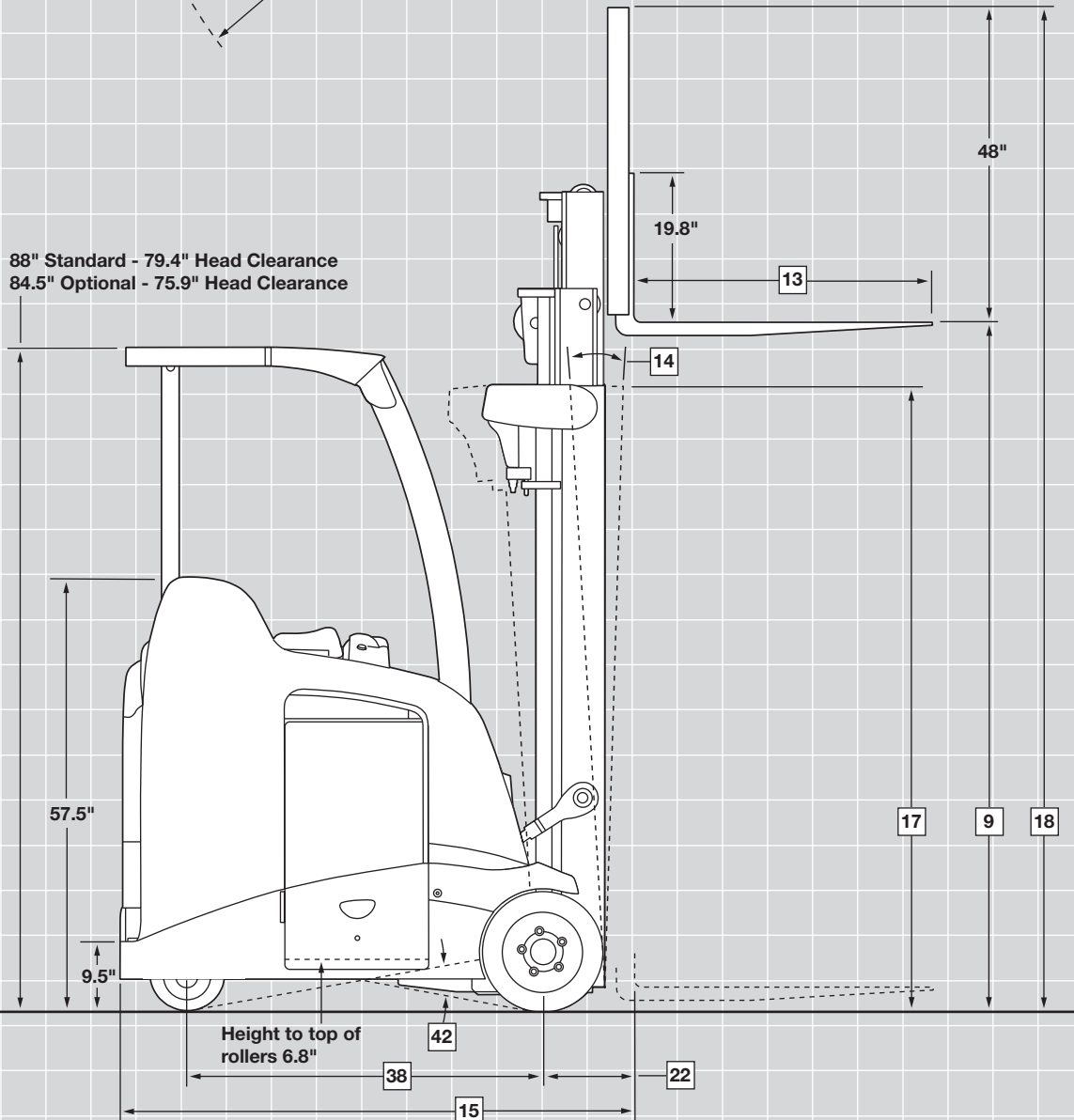
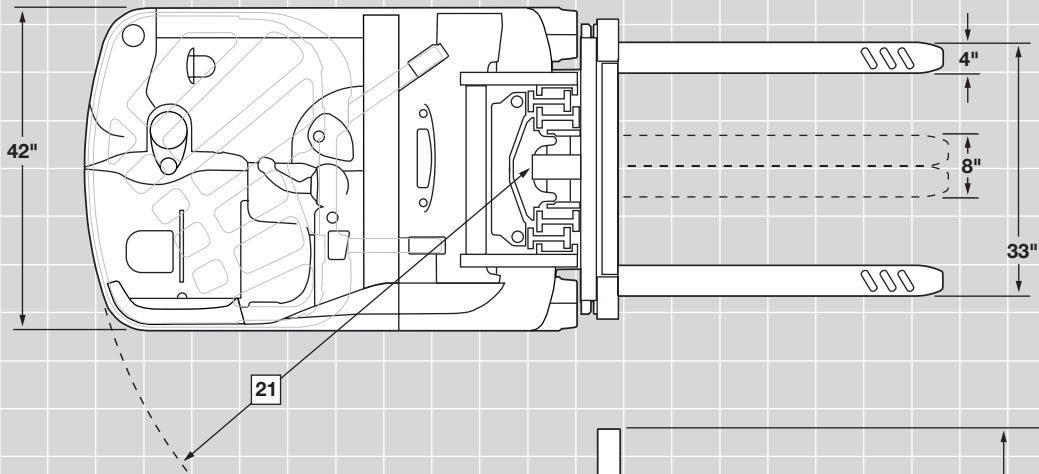

RC 5500 Series

Specifications

		Manufacturer		Crown Equipment Corporation						
		Model	RC	5510/15-30	5520/25-30	5530/35-30	5530/35-35	5540/45-40		
General Information	1	Manufacturer		Crown Equipment Corporation						
	2	Model	RC	5510/15-30	5520/25-30	5530/35-30	5530/35-35	5540/45-40		
	3	Load Capacity*	Rated to 154 in	lb	3000	3000	3000	3500	4000	
	4	Load Center	Fork Face to Load CG	in	24					
	5	Power	Electric	36 Volts						
	6	Operator Type		Stand-up Rider Counterbalanced						
	7	Tire Type	Press-on Solid	Cushion						
	8	Wheels (x = driven)	Number Front/Rear	2x / 2						
Dimensions	9	Mast	Lifting Height	in	See Mast Chart					
	11		Free Lift Height†	in	See Mast Chart					
	12	Fork Carriage		ITA Class II						
	13	Forks	Standard L x W x T	in	36 x 4 x 1.5	36 x 4 x 1.5	36 x 4 x 1.5	36 x 4 x 1.75	36 x 4 x 1.75	
			Optional Lengths	in	30, 39, 42, 45, 48, 54, 60					
	14	Tilt	B°/F°	degree	See Mast Chart					
	15	Headlength**		in	62.9	65.2	67.5	67.7	70.1	
	16	Width Overall		in	42					
	17	Height	Mast Collapsed	in	See Mast Chart					
	18		Mast Extended†	in	See Mast Chart					
	21	Turning Radius		in	51.7	54	56.2	56.2	58.6	
	22	Load Distance**	Center of Wheel to Fork Face	in	11.3		11.5			
	23	Aisle Width	Right Angle Stack	in	Turn Radius + Load Distance + Load Length + Clearance					
Speeds	24	Speed Travel	Empty/Loaded	36V mph	7.2/7.2					
	24A	w/Productivity Package	Empty/Loaded	36V mph	7.8/7.2					
	25	Speed Lift	DC	Empty/Loaded	fpm	90/60	90/60	90/60	90/57	90/50
			AC	Empty/Loaded	fpm	110/65	110/65	110/65	110/60	110/55
	26	Speed Lower	Empty/Loaded	fpm	90/90					
Weights	32	Weight, Less Battery		lb	6350	6390	5929	6429	6457	
	33	Axle Load with Max Battery	Unloaded Front	lb	3992	4167	4522	4557	4850	
			Unloaded Rear	lb	4337	4489	4057	4521	4678	
	34									
Chassis	35	Tires	Number Front/Rear	2 / 2						
	36		Size Front	in	16 x 7 x 10.5					
	37		Size Rear	in	10 x 5 x 6.5					
	38	Wheelbase		in	42.7	45	47.2	47.2	49.6	
	39	Tread Width	Front - Drive	in	35					
			Rear - Steer	in	6.7					
	40	Ground Clearance, Loaded	Lowest Point	in	3.0					
	41		Center of Wheelbase	in	4.2					
	42	Grade Clearance, Loaded		%	41	39	37	37	35	
	43	Brakes	Service	Foot - Motor						
Parking			Auto - Electric							
Battery	45	Battery	Type	Lead Acid						
			Compartment	B	C	D	D	E		
	46		Capacity	AH	775	930	1085	1085	1240	
				KWH	27.2	32.6	38.1	38.1	43.6	
	47		Weight - Min	lb	1710	1990	2280	2280	2600	
			Weight - Max	lb	1980	2270	2650	2650	3070	
			Comp't. Size - Max	Length	13.6	15.9	18.2	18.2	20.5	
				Width	38.56					
		Height	31							
48	Battery Floor Height	With Rollers	in	6.8						
Motors	49	Motors	Traction Motor, dia	in	7.5					
			Lift Motor, dia	DC/AC in	6.7/7.5					
	51	Operating Pressure	For Attachments	psi	Up to 2500 psi					

* Optional masts, attachments, longer load dimensions and higher lifting heights may result in derating of the capacity. Contact your local dealer.

** Add 4.25 inches for quad masts; add 2 inches for sideshift option.

† Includes load backrest.

Performance specifications are based on a truck equipped with a 190" triple telescopic mast.

Mast Type			TT					QUAD				
9	Lifting Height	in	154	190	208	226	244	240	246	258	264	276
11	Free Lift Height	in	20.2	32.2	38.2	44.2	50.2	33.2	36.2	39.2	42.2	45.2
14	Tilt B/F*	degree	3/5	5/5	5/5	5/5	5/5	3/5	3/5	3/5	3/5	3/5
17	Mast Collapsed Height	in	71.3	83.3	89.3	95.3	101.3	83.4	86.4	89.4	92.4	95.4
18	Mast Extended Height	in	202	238	256	274	292	288	294	306	312	324

All values with 48" Load Backrest
 *Forward Tilt limited to 2° above staging

Standard Equipment

- Crown's Access 1 2 3® Comprehensive System Control
- e-GEN™ Braking System with automatic parking brake
- Intrinsic Stability System™
 - Travel speed reduction and appropriate brake control when forks are above free lift
 - Forward tilt interlock above staging
 - Controlled tilt speeds
 - Counterweight exceeds required standards
 - Cornering speed control
 - Ramp hold
 - Ramp speed control
- FlexRide™ Suspension
- Operator compartment
 - Crown flexible side stance
 - Padded back support with integral side restraint
 - Premium rubber floor mat
 - Padded arm rest
 - Operator console with desk top work surface and storage
 - Entry bar
 - Posture relief step
- Multi-task control handle
- Tilt position assist
- Crown display
 - Battery discharge indicator with lift interrupt and re-key feature
 - Hour meters / travel distance / stop watch
 - Pin code access capable
 - Event code display with five (5) key navigation
 - Access 1 2 3 diagnostics
 - P1, P2, P3 Performance tuning
- AC traction system
- 36-volt system
- 350 amp battery connector

- InfoPoint® System with Quick Reference Guide
- Color-coded wiring
- Battery rollers
- Dual 10" cushion steer tires
- Large 16" cushion drive tires
- Crown-manufactured drive and lift motors
- High visibility power unit
- Radial design overhead guard with third post
- High visibility mast with in-line hose routing
- Hydrostatic power steering
- 5° forward tilt
- 48" high load backrest
- Reverse steering

Optional Equipment

- AC Hydraulics
- Productivity package
- Operator compartment wall padding
- Adjustable armrest
- Freezer and corrosion conditioning
- Sideshifter
- Hydraulic valves for attachments
- Quick disconnect hydraulic connectors
- Forward steering
- EE rating
- InfoLink™ Ready System
- Keyless on/off switch
- Fork lengths
- Polished and tapered forks
- Load backrest heights
- Non-marking smooth or lug rubber tires
- Drive-in rack overhead guard
- Overhead guard heights
- Tilt options
- Work lights
- Strobe lights
- Audible travel alarms

RC 5500 Series

- Suspended floorboard
- Positive/Negative accessory cable
- Work Assist™ Accessories
 - Clip pad and hook
 - Clamp
 - Clamp and mounting plate
 - Operator fan
 - Fire extinguisher
 - Dome light
 - Storage Pocket
- Drive Axle Debris Guard
- LED worklights with plastic lenses

Operator Compartment

Soft, rounded surfaces make the compartment interior more comfortable. Streamlined exterior smooths entry/exit for the operator.

A low floor height, (9.5") first greets the operator. A patented FlexRide suspended floor provides a comfortable ride for a wide range of operators. A footrest provides postural relief during stationary tasks, complementing the largest floorboard in its class.

Crown's flexible side stance allows the operator to change positions to increase comfort and productivity.

An entry bar with sensors automatically slows travel and sounds an audible alarm when activated, encouraging safe foot positioning inside the truck.

The Multi-Task Control Handle naturally bridges Crown's current and past designs. Intuitive operation is increased, reducing the learning curve. Blending of hydraulic control functions and traction can improve productivity. Control handle activation forces are reduced. Soft grip steer tiller with hydrostatic steering reduces operator fatigue.

Technical Information

Operator visibility is improved with:

- Low-profile sculpted power unit
- High visibility mast
- Angled overhead guard post and placement
- Radial design overhead guard
- Flexible side stance

Crown Drive System

Crown has applied the latest generation AC drive system, enhanced with Access 1 2 3 technology. The demand for high efficiency systems that closely match customer torque requirements is met with this generation control system. Crown-manufactured, independently controlled, AC drive motors are specifically designed to optimize system integration between the traction and braking controls.

Crown's Access 1 2 3 technology provides optimum performance and control by offering a communication interface for operators and technicians, intelligent coordination of lift truck system and simplified service with advanced diagnostics.

The Crown display is used for easy troubleshooting, access service history and set performance features. A distribution panel is conveniently located with all test points, control fuses and central wiring for easy troubleshooting.

Three modes of performance can be selected to accommodate operator experience or application requirements.

e-GEN™ Braking System

Variable regenerative motor braking is optimized and virtually eliminates brake maintenance.

The appropriate amount of stopping force is applied to match operator brake input and the current operating conditions of the truck.

The closed loop Access 1 2 3 traction control will keep the truck static until a travel input is requested, even when operating on a grade.

Automatic electric parking brakes activate when the operator releases the brake pedal, a travel input has not been requested or battery power has been disconnected.

Steering

Load-sense hydrostatic steering is an on-demand system which reduces energy consumption. Smooth, quiet steering control with minimal operator effort required at the steer tiller. Steer tires rotate 182° for maximum maneuverability. Crown's hydrostatic steering system is simplified with significantly fewer parts, thus reducing maintenance requirements.

Hydraulics

The hydraulic system provides continuous filtration. A pressurized steel hydraulic tank reduces oil misting and contamination. Hydraulic attachments can be added easily in the field.

Hydraulic manifold is mounted on the mast reducing the number of hoses and fittings.

Ram displacement type lift cylinders and two double acting tilt cylinders are Crown-manufactured. All rams and piston rods are hard chrome plated to reduce pitting and extend cylinder packing life. O-ring face seal fittings are used to eliminate leaks.

Mast Assembly

Crown-manufactured mast assembly utilizes a "flush-face" interlocked I-beam design to improve visibility and reduce truck length. Roller bearing studs are welded on both sides of the rails for maximum strength and roller bearings are canted to run in the thick cross section of the rail. Tie bars wrap around the rails for added strength and to resist off-center load forces.

"In-line" hose routing opens up visibility. Cylinders are placed to the sides to create a high visibility design.

The mast has four points of attachment to the truck for good load force distribution. Two mounting points are at the frame, where tilt cylinders attach. Tilt cylinders use spherical bushings to resist off center load distortions. Two large diameter studs secure the mast to the drive units.

Drive Units

Two Crown-manufactured independent double reduction planetary gear drives offer 27 to 1 gear reduction. The first and second reduction use helical gears for low noise and efficiency. The drive unit gears are splash lubricated in an oil bath.

Carriage

An ITA Class II carriage is standard. An optional hook type ITA sideshifter or other attachments are easily added. Optional fork lengths are available.

Other Options

1. Audible travel alarm
2. Flashing lights

Safety considerations and dangers associated with audible travel alarms and flashing lights include:

- Multiple alarms and/or lights can cause confusion.
- Workers ignore the alarms and/or lights after day-in and day-out exposure.
- Operator may transfer the responsibility for "looking out" to the pedestrians.
- Annoys operators and pedestrians.

Other Options Available

Contact your local Crown dealer.

Dimensions and performance data given may vary due to manufacturing tolerances. Performance is based on an average size vehicle and is affected by weight, condition of truck, how it is equipped and the conditions of the operating area. Crown products and specifications are subject to change without notice.



Crown Equipment Corporation
New Bremen, Ohio 45869 USA
Tel 419-629-2311
Fax 419-629-3796
crown.com

You can count on Crown to build lift trucks designed for safe operation, but that's only part of the safety equation. Crown encourages safe operating practices through ongoing operator training, safety-focused supervision, maintenance and a safe working environment. Go to crown.com and view our safety section to learn more.

Because Crown is continually improving its products, specifications are subject to change without notice.

Crown, the Crown logo, the color beige, the Momentum symbol, Access 1 2 3, InfoLink, InfoPoint, e-GEN, FlexRide, Intrinsic Stability System and Work Assist are trademarks of Crown Equipment Corporation.

Copyright 2007-2009 Crown Equipment Corporation
SF14737 Rev. 12/09
Printed in U.S.A.