

CROWN

SP 3500 SP 4000 SERIES

Profile Sheet

Stockpicker



SP 3500/4000 Series

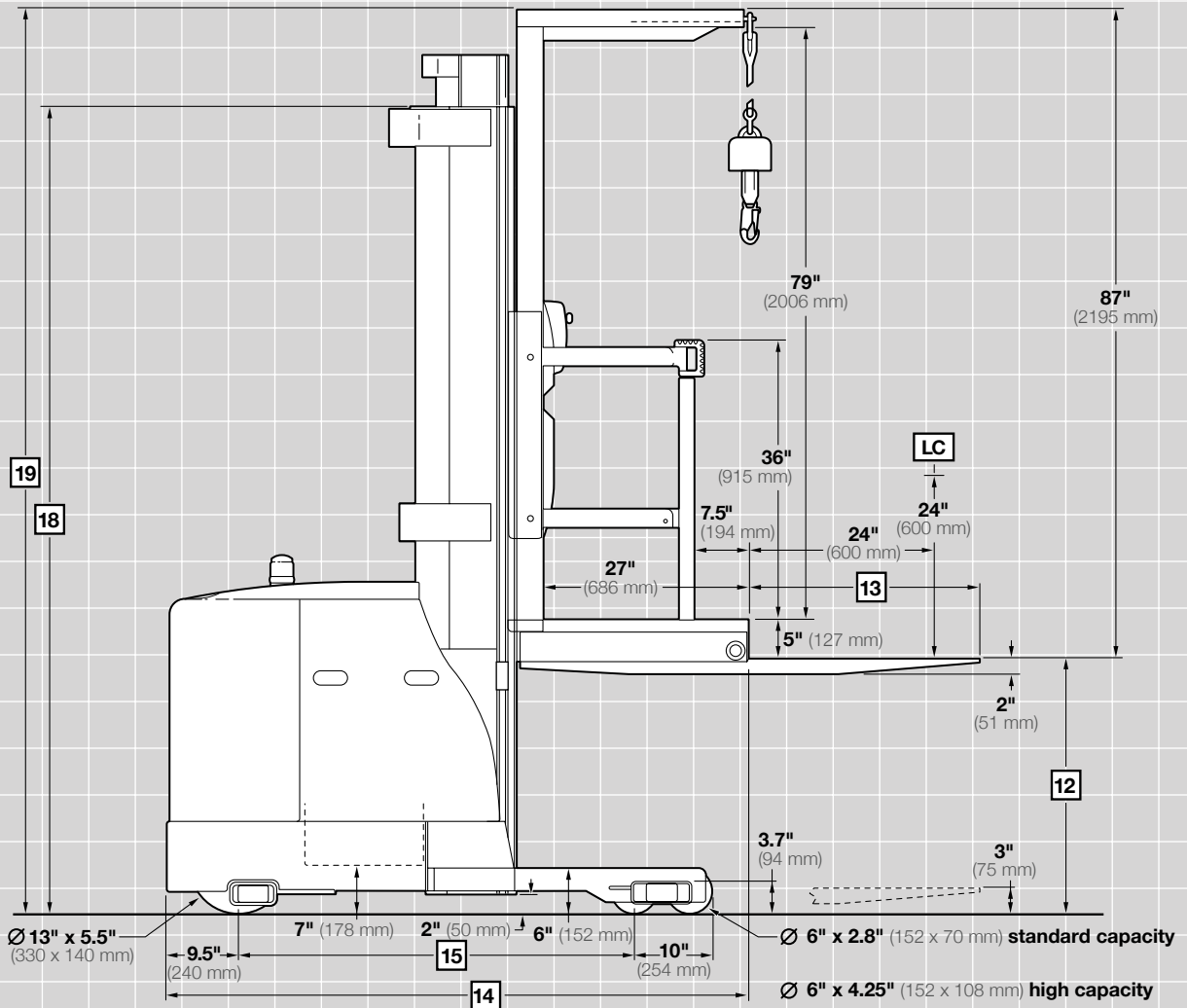
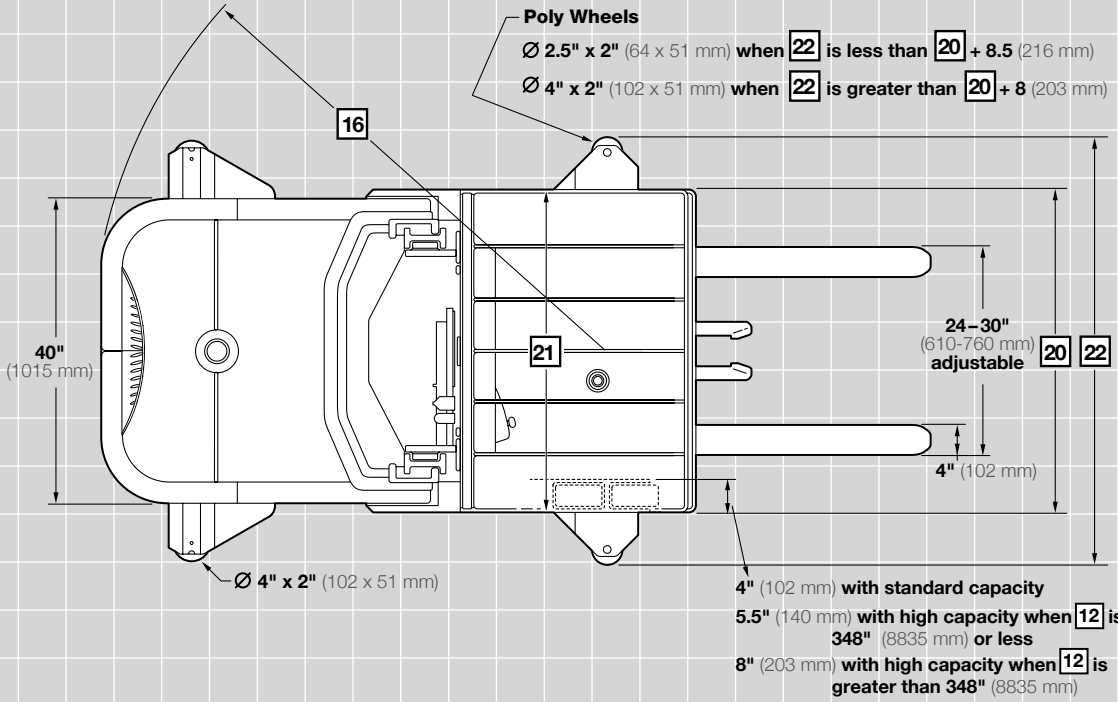

SP 3500/4000 Series

			Imperial	Metric	
General	1	Manufacturer	Crown Equipment Corporation		
	2	Model	SP 3500-30		
	3	Load Capacity*	lb kg	See Chart	
	4	Load Center	Platform face to load CG in mm	24 600	
	5	Power	Electric volts	24 24	
	6	Operator Type	Stand-up Rider	Stockpicker	
	7	Tire Type	Load/Drive	Poly/Poly	
Dimensions	11	Wheels (x = driven)	Load/Drive	4/1x	
	12	Lifting Height	in mm	See Chart	
	13	Forks	Standard L x W x T in mm	36 x 4 x 2	915 x 102 x 51
			Optional Lengths in mm	30, 39, 42, 45, 48, 54, 60, 72, 84	760, 990, 1070, 1145, 1220, 1370, 1525, 1830, 2135
	Battery Compartment				
	14	Head Length	TL in mm	74.6	1895
			TT in mm	75.6	1920
	15	Wheel Base	TL in mm	52	1320
			TT in mm	51	1300
	16	Turning Radius	TL in mm	69	1755
TT in mm			68	1735	
Battery	17	Battery -Width is measured on the sides of the battery with lifting hooks	Type	Lead Acid "AA"	Lead Acid "B"
			Min Weight/Max Amp lb amp kg amp	975/660	1520/1085
				442/660	689/1085
			Max Battery Size L x W x H in mm	31.75 x 13.12 x 23.25	36.25 x 14.25 x 31
			806 x 333 x 590	921 x 362 x 787	

*Contact factory. Capacity may be subject to derating, depending upon lifting height, load center and fork length.

			TL											
12	Lifting Height	in mm	136	3450	148	3755	172	4365	194	4925	214	5435	195	
	Load Capacity	Standard	lb t	3000	1.3	3000	1.3	3000	1.3	3000	1.3	3000	1.3	3000
		High	lb t	na	na	na	na	na	na	na	na	na	na	na
	Free Lift	in mm	3	75	6	155	6	155	6	155	6	155	3	
18	Collapsed Height	in mm	89.5	2270	95	2410	107	2715	119	3020	131	3325	89.5	
19	Extended Height	in mm	223	5670	235	5975	259	6585	281	7145	301	7650	283	
20	Straddle Width	in mm	42	1065	42	1065	42	1065	42	1065	42	1065	42	
21	Operator Compartment Width	in mm	42	1065	42	1065	42	1065	42	1065	42	1065	42	
22	Aisle Guide Wheel Range †	in mm	45.50 to 65.25	1156 to 1658	45.50 to 65.25	1156 to 1658	45.50 to 65.25	1156 to 1658	45.50 to 65.25	1156 to 1658	45.50 to 65.25	1156 to 1658	45.50 to 65.25	
	Truck Weight Without Battery	lb kg	5130	2332	5189	2358	5319	2418	5607	2548	5737	2608	5704	

† In 0.25" (6 mm) increments

†† 48" (1220 mm) straddle width on "AA battery" only

††† 36V is high capacity when lift height is greater than 240"

Imperial		Metric					
Crown Equipment Corporation							
SP 4000-30							
See Chart							
24		600					
36		36					
Stockpicker							
Poly/Poly							
4/1x							
See Chart							
36 x 4 x 2		915 x 102 x 51					
30, 39, 42, 45, 48, 54, 60, 72, 84		760, 990, 1070, 1145, 1220, 1370, 1525, 1830, 2135					
B		C		D		E	
74.6	1895	76.9	1953	78.5	1994	81.1	2060
75.6	1920	77.9	1979	79.5	2019	82.1	2085
52	1321	54	1378	56	1419	59	1486
51	1302	53	1359	55	1400	58	1467
69	1753	71	1803	73	1854	75.5	1918
68	1727	70	1778	72	1829	74.5	1892
Lead Acid "B"		Lead Acid "C"		Lead Acid "D"		Lead Acid "E"	
1700/775		2000/930		2280/1085		2600/1240	
770/775		907/930		1034/1085		1179/1240	
38.44 x 14.25 x 31		38.44 x 16.25 x 31		38.69 x 18.19 x 31		38.69 x 20.75 x 31	
976 x 362 x 787		976 x 413 x 787		983 x 462 x 787		983 x 527 x 787	

TT																
4950	210	5330	240	6095	276	7010	294	7465	312	7920	330	8380	348	8835	366	9295
1.3	3000	1.3	3000	1.3	2000	0.9	1750	0.7	1500	0.6	na	na	na	na	na	na
na	na	na	na	na	2500	1.1	2350	1.1	2200	1.0	2050	0.9	1900	0.9	1750	0.7
75	8	215	20	520	32	825	38	980	44	1130	56	1435	62	1590	68	1740
2270	95	2410	107	2715	119	3025	125	3175	131	3325	143	3630	149	3780	155	3935
7175	298	7555	328	8320	364	9230	382	9690	400	10145	418	10605	436	11060	454	11520
1065	42	1065	42††	1065	48	1220	54	1370	54	1370	56	1420	60	1525	60	1525
1065	42	1065	42	1065	48	1220	54	1370	54	1370	54	1370	60	1525	60	1525
1156 to 1658	45.50 to 65.25	1156 to 1658	45.50 to 65.25	1156 to 1658	48.75 to 71.25	1240 to 1810	54.75 to 77.25	1390 to 1962	54.75 to 77.25	1390 to 1962	56.75 to 79.25	1440 to 2013	60.75 to 83.25	1543 to 2115	60.75 to 83.25	1543 to 2115
2592	5789	2631	5975	2716	6453	2933	6636	3016	6728	3058	6924	3147	7094	3224	7524	3420



You can count on Crown to build lift trucks designed for safe operation, but that's only part of the safety equation. Crown encourages safe operating practices through ongoing operator training, safety-focused supervision, maintenance and a safe working environment. Go to crown.com and view our safety section to learn more.

Crown Equipment Corporation
New Bremen, Ohio 45869 USA
Tel 419-629-2311
Fax 419-629-3796
crown.com

Because Crown is continually improving its products, specifications are subject to change without notice.

Crown, the Crown logo, the color beige, the Momentum symbol, are trademarks of Crown Equipment Corporation.

Copyright 2010-2013 Crown Equipment Corporation
SF18481 Rev. 08/13
Printed in U.S.A.