

CROWN

Specifications

FC 4500 Series

Sit-down Rider
Lift Truck

FC 4500

Series



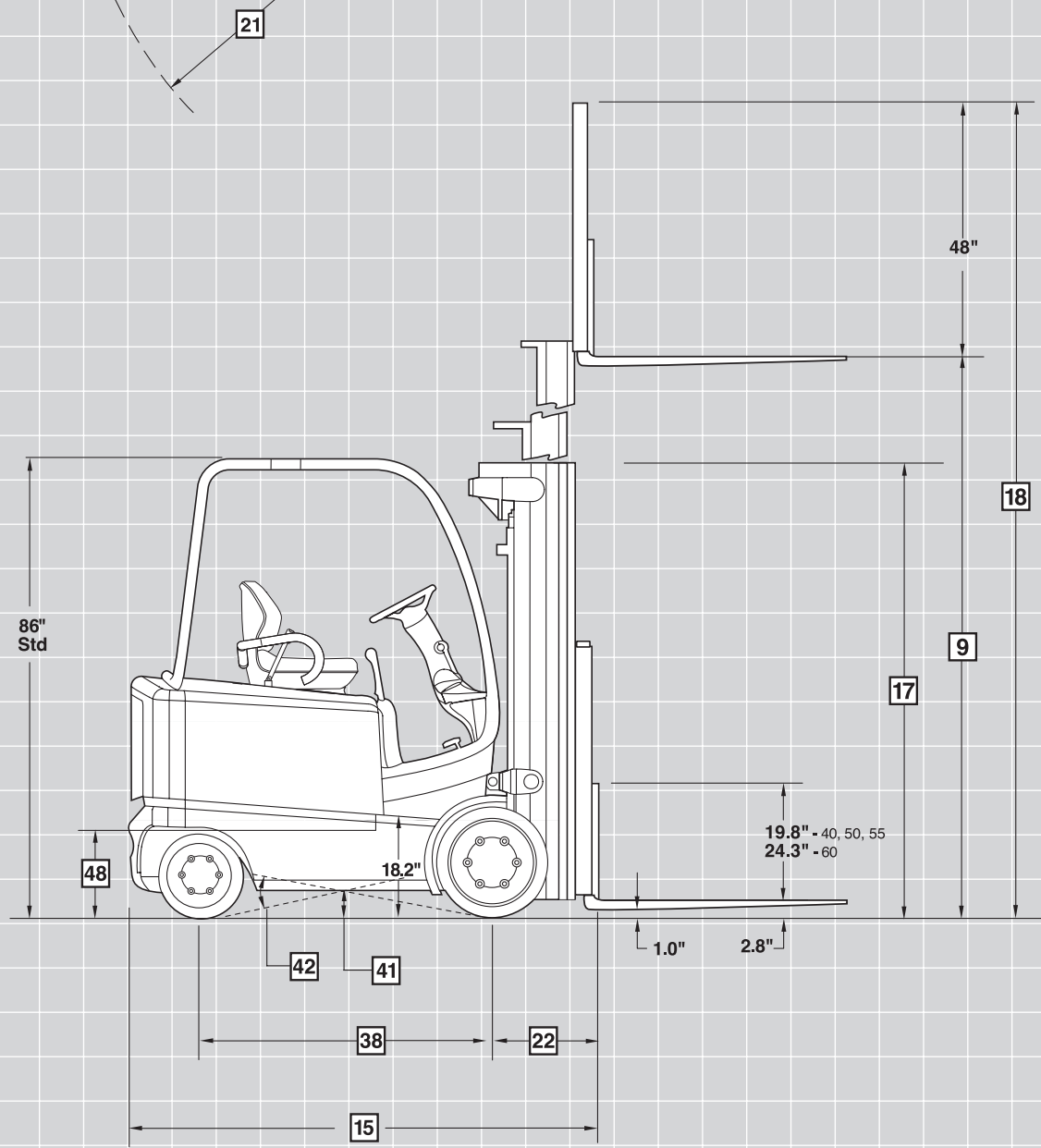
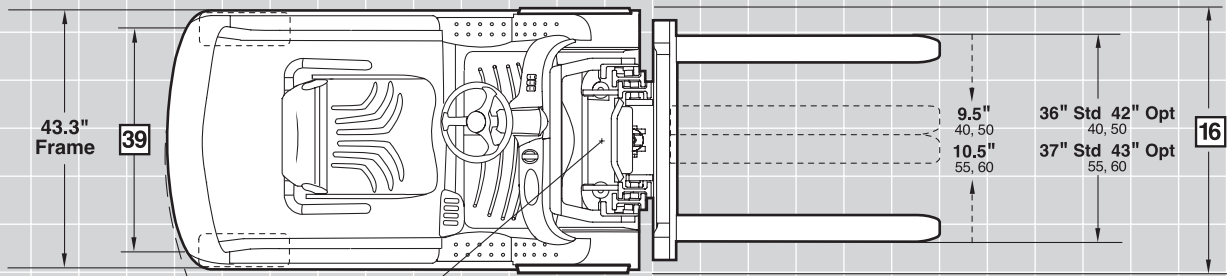

FC 4500 Series

Specifications

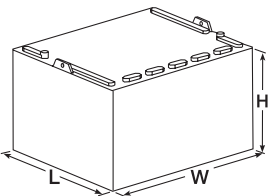
				Crown Equipment Corporation			
				FC 4510/15-40	FC 4520/25-40		
General Information	1	Manufacturer		Crown Equipment Corporation			
	2	Model		FC 4510/15-40	FC 4520/25-40		
	3	Load Capacity*	lb	4000			
	4	Load Center	Fork Face to Load CG	in	24		
	5	Power	Electric	36-Volt / 48-Volt			
	6	Operator Type		Sit-down Rider Counterbalanced			
	7	Tire Type		Cushion			
	8	Wheels (x = driven)	Number Front/Rear	2x / 2			
Dimensions	9	Mast (See Mast Chart)	Lifting Height (MFH)	in	188		
			Free Lift Height	in	32.2		
	12	Fork Carriage		ITA Class II			
	13	Forks	Standard L x W x T	in	36 x 4 x 1.8		
			Optional Lengths	in	42, 48, 54, 60		
	14	Tilt	F° / B°	degree	5 / 5		
			Interlocked Fork Height**	in	66		
		Battery Compartment		in	27	33	
	15	Headlength	Length to Fork Face	in	77.8	84	
	16	Width Overall	Standard Tread	in	43.4		
			Wide Tread	in	47.5		
	17	Height with Load Backrest	Mast Collapsed	in	83		
			Mast Extended	in	236		
	21	Turning Radius		in	69.1	75.3	
22	Load Distance	Center of Wheel to Fork Face	in	15.8			
23	Aisle Width (Add Load + Clear)	Right Angle Stack	in	84.9	91.1		
Performance	24	Speed Travel	Empty / Loaded 48V	mph	11 / 10.2		
			Empty / Loaded 36V	mph	9 / 8.3		
	25	Speed Lift††	DC	Empty / Loaded 48V	fpm	110 / 76	
				Empty / Loaded 36V	fpm	76 / 58	
			AC	Empty / Loaded 48V	fpm	110 / 92	
				Empty / Loaded 36V	fpm	104 / 71	
26	Speed Lower	Empty / Loaded	fpm	90			
Weights	32	Weight, Less Battery		lb	7,243	7,195	
	33	Axle Load with Max Battery, Loaded	Front	lb	11,987	11,752	
			Rear	lb	1,886	2,242	
	34	Axle Load with Max Battery, Unloaded	Front	lb	4,787	4,851	
Rear			lb	5,086	5,144		
Chassis	36	Tires	Size Front	in	21 x 7 x 15		
	Size Rear		in	16 x 6 x 10.5			
	38	Wheelbase		in	49.7	54.7	
	39	Tread/Track Width	Front Standard / Rear	in	36.4 / 36		
			Front Optional / Rear	in	40.5 / 36		
	40	Ground Clearance, Loaded	Lowest Point	in	3		
	41		Center of Wheelbase	in	4.8		
	42	Grade Clearance, Loaded		%	38	35	
43	Brakes	Service	Foot Hydraulic				
		Parking	Hand Electro-hydraulic				
Battery	45	Battery	Type	Lead Acid			
			Capacity - 36V	AH	1210	1430	
	46			kWh	42.5	50.2	
				Capacity - 48V	AH	880	1100
	47			kWh	41.2	51.5	
				Weight - Min	lb	2630	2800
				Weight - Max	lb	3200	4000
				Size - Max	Length	27.25	32.94
					Width	38.69	
					Height	22.25	
48	Battery Floor Height	With Rollers / w/o Rollers	in	17.4 / 17.1			
Motors	49	Motors	Tractor Motor, dia	in	11.4		
	50		Lift Motor, dia	in	7.2		
51	Operating Pressure	For Attachments	psi	Up to 3000			

* Optional masts, attachments, longer load dimensions and higher lifting heights may result in derating of the capacity. Contact local dealer.

** Forward tilt restricted to 2° above this height.

† With maintenance-free batteries or batteries with a lid (flat top), consult factory.

†† Based on TT mast.

FC 4500 Series

Specifications

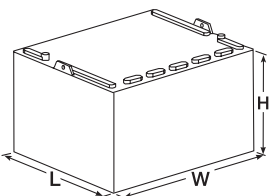
	General Information		Crown Equipment Corporation			
	1	Manufacturer				
	2	Model	FC 4510/15-50	FC 4520/25-50	FC 4540/45-50	
	3	Load Capacity*	5000			
	4	Load Center	Fork Face to Load CG	24		
	5	Power	Electric			
	6	Operator Type	Sit-down Rider Counterbalanced			
	7	Tire Type	Cushion			
	8	Wheels (x = driven)	Number Front/Rear 2x / 2			
Dimensions	9	Mast (See Mast Chart)	Lifting Height (MFH)	188		
			Free Lift Height	32.2		
	12	Fork Carriage	ITA Class II			
	13	Forks	Standard L x W x T	36 x 4 x 1.8		
			Optional Lengths	42, 48, 54, 60		
	14	Tilt	F° / B°	5 / 5		
			Interlocked Fork Height**	66		
		Battery Compartment		27	33	36
	15	Headlength	Length to Fork Face	81.2	84	87.1
	16	Width Overall	Standard Tread	43.4		
			Wide Tread	47.5		
	17	Height with Load Backrest	Mast Collapsed	83		
18	Mast Extended		236			
21	Turning Radius		71.9	75.4	78.0	
22	Load Distance	Center of Wheel to Fork Face	15.8			
23	Aisle Width (Add Load + Clear)	Right Angle Stack	87.7	91.2	93.8	
Performance	24	Speed Travel	Empty / Loaded 48V	10.9 / 9.9		
			Empty / Loaded 36V	8.8 / 8.0		
	25	Speed Lift††	DC	Empty / Loaded 48V	110 / 70	
				Empty / Loaded 36V	76 / 50	
			AC	Empty / Loaded 48V	110 / 86	
				Empty / Loaded 36V	104 / 66	
26	Speed Lower	Empty / Loaded	90			
Weights	32	Weight, Less Battery		8,090	7,736	7,454
	33	Axle Load with Max Battery, Loaded	Front	13,616	13,641	13,456
			Rear	2,103	1,895	2,097
	34	Axle Load with Max Battery, Unloaded	Front	4,616	5,014	4,829
	Rear		6,104	5,522	5,724	
Chassis	36	Tires	Size Front	21 x 8 x 15		
	37		Size Rear	16 x 6 x 10.5		
	38	Wheelbase		49.7	54.7	54.7
	39	Tread/Track Width	Front Standard / Rear	35.4 / 36		
			Front Optional / Rear	39.5 / 36		
	40	Ground Clearance, Loaded	Lowest Point	3		
	41		Center of Wheelbase	4.8		
	42	Grade Clearance, Loaded		38	35	35
43	Brakes	Service	Foot Hydraulic			
44		Parking	Hand Electro-hydraulic			
Battery	45	Battery	Type	Lead Acid		
	46		Capacity - 36V	1210	1430	1650
			kWh	42.5	50.2	57.9
		Capacity - 48V	880	1100	1210	
			kWh	41.2	51.5	56.6
	47		Weight - Min	2630	2800	3100
			Weight - Max	3200	4000	4250
			Size - Max	Length	27.25	32.94
	Width			38.69		
	Height			22.25		
48	Battery Floor Height	With Rollers / w/o Rollers	17.4 / 17.1			
Motors	49	Motors	Tractor Motor, dia	11.4		
	50		Lift Motor, dia	7.2		
51	Operating Pressure	For Attachments	psi Up to 3000			

* Optional masts, attachments, longer load dimensions and higher lifting heights may result in derating of the capacity. Contact local dealer.

** Forward tilt restricted to 2° above this height.

† With maintenance-free batteries or batteries with a lid (flat top), consult factory.

†† Based on TT mast.

FC 4500 Series

Specifications

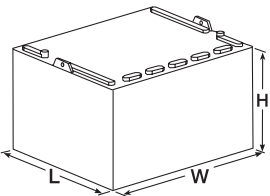
				Crown Equipment Corporation			
				FC 4520/25-55	FC 4540/45-55		
General Information	1	Manufacturer		Crown Equipment Corporation			
	2	Model		FC 4520/25-55	FC 4540/45-55		
	3	Load Capacity*	lb	5500			
	4	Load Center	Fork Face to Load CG	in	24		
	5	Power	Electric	36-Volt / 48-Volt			
	6	Operator Type		Sit-down Rider Counterbalanced			
	7	Tire Type		Cushion			
	8	Wheels (x = driven)	Number Front/Rear	2x / 2			
Dimensions	9	Mast (See Mast Chart)	Lifting Height (MFH)	in	188		
			Free Lift Height	in	32.2		
	12	Fork Carriage		ITA Class II			
	13	Forks	Standard L x W x T	in	36 x 5 x 1.8		
			Optional Lengths	in	42, 48, 54, 60		
	14	Tilt	F° / B°	degree	5 / 5		
			Interlocked Fork Height**	in	66		
		Battery Compartment		in	33	36	
	15	Headlength	Length to Fork Face	in	87.4	90.5	
	16	Width Overall	Standard Tread	in	45.2		
			Wide Tread	in	48		
	17	Height with Load Backrest	Mast Collapsed	in	83		
			Mast Extended	in	236		
	21	Turning Radius		in	78.2	80.9	
	22	Load Distance	Center of Wheel to Fork Face	in	15.8		
23	Aisle Width (Add Load + Clear)	Right Angle Stack	in	94.0	96.7		
Performance	24	Speed Travel	Empty / Loaded 48V	mph	10.8 / 9.7		
			Empty / Loaded 36V	mph	8.8 / 7.8		
	25	Speed Lift††	DC	Empty / Loaded 48V	fpm	110 / 68	
				Empty / Loaded 36V	fpm	76 / 47	
			AC	Empty / Loaded 48V	fpm	110 / 81	
				Empty / Loaded 36V	fpm	104 / 62	
26	Speed Lower	Empty / Loaded	fpm	90			
Weights	32	Weight, Less Battery		lb	8,285	8,166	
	33	Axle Load with Max Battery, Loaded	Front	lb	14,308	14,111	
			Rear	lb	2,277	2,655	
	34	Axle Load with Max Battery, Unloaded	Front	lb	4,818	4,622	
Rear			lb	6,267	6,644		
Chassis	36	Tires	Size Front	in	21 x 9 x 15		
			Size Rear	in	16 x 7 x 10.5		
	38	Wheelbase		in	54.7	54.7	
	39	Tread/Track Width	Front Standard / Rear	in	36.2 / 36		
			Front Optional / Rear	in	39 / 36		
	40	Ground Clearance, Loaded	Lowest Point	in	3		
	41		Center of Wheelbase	in	4.8		
42	Grade Clearance, Loaded		%	35	35		
43	Brakes	Service	Foot Hydraulic				
		Parking	Hand Electro-hydraulic				
Battery	45	Battery	Type	Lead Acid			
			Capacity - 36V	AH	1430	1650	
	46			kWh	50.2	57.9	
				Capacity - 48V	AH	1100	1210
	47			kWh	51.5	56.6	
				Weight - Min	lb	2800	3100
				Weight - Max	lb	4000	4250
				Size - Max	Length	32.94	36.38
					Width	38.69	
					Height	22.25	
48	Battery Floor Height	With Rollers / w/o Rollers	in	17.4 / 17.1			
Motors	49	Motors	Tractor Motor, dia	in	11.4		
	50		Lift Motor, dia	in	7.2		
51	Operating Pressure	For Attachments	psi	Up to 3000			

* Optional masts, attachments, longer load dimensions and higher lifting heights may result in derating of the capacity. Contact local dealer.

** Forward tilt restricted to 2° above this height.

† With maintenance-free batteries or batteries with a lid (flat top), consult factory.

†† Based on TT mast.

FC 4500 Series

Specifications

				Crown Equipment Corporation			
				FC 4520/25-60	FC 4540/45-60		
General Information	1	Manufacturer		Crown Equipment Corporation			
	2	Model		FC 4520/25-60	FC 4540/45-60		
	3	Load Capacity*	lb	6000			
	4	Load Center	Fork Face to Load CG	in	24		
	5	Power	Electric	36-Volt / 48-Volt			
	6	Operator Type		Sit-down Rider Counterbalanced			
	7	Tire Type		Cushion			
	8	Wheels (x = driven)	Number Front/Rear	2x / 2			
Dimensions	9	Mast (See Mast Chart)	Lifting Height (MFH)	in	180		
			Free Lift Height	in	32.2		
	12	Fork Carriage		ITA Class III			
	13	Forks	Standard L x W x T	in	36 x 5 x 1.8		
			Optional Lengths	in	42, 48, 54, 60		
	14	Tilt	F° / B°	degree	5 / 5		
			Interlocked Fork Height**	in	66		
		Battery Compartment		in	33	36	
	15	Headlength	Length to Fork Face	in	87.7	90.8	
	16	Width Overall	Standard Tread	in	45		
			Wide Tread	in	48		
	17	Height with Load Backrest	Mast Collapsed	in	83		
			Mast Extended	in	228		
	21	Turning Radius		in	78.2	80.9	
22	Load Distance	Center of Wheel to Fork Face	in	16.1			
23	Aisle Width (Add Load + Clear)	Right Angle Stack	in	94.3	97.0		
Performance	24	Speed Travel	Empty / Loaded 48V	mph	10.8 / 9.5		
			Empty / Loaded 36V	mph	8.8 / 7.6		
	25	Speed Lift††	DC	Empty / Loaded 48V	fpm	110 / 66	
				Empty / Loaded 36V	fpm	76 / 43	
			AC	Empty / Loaded 48V	fpm	110 / 76	
				Empty / Loaded 36V	fpm	104 / 57	
	26	Speed Lower	Empty / Loaded	fpm	90		
Weights	32	Weight, Less Battery		lb	8,687	8,226	
	33	Axle Load with Max Battery, Loaded	Front	lb	15,364	15,078	
			Rear	lb	2,124	2,248	
	34	Axle Load with Max Battery, Unloaded	Front	lb	4,984	4,699	
Rear			lb	6,503	6,627		
Chassis	36	Tires	Size Front	in	21 x 9 x 15		
			Size Rear	in	16 x 7 x 10.5		
	38	Wheelbase		in	54.7	54.7	
	39	Tread/Track Width	Front Standard / Rear	in	36.2 / 36		
			Front Optional / Rear	in	39 / 36		
	40	Ground Clearance, Loaded	Lowest Point	in	3		
	41		Center of Wheelbase	in	4.8		
42	Grade Clearance, Loaded		%	35	35		
43	Brakes	Service	Foot Hydraulic				
		Parking	Hand Electro-hydraulic				
Battery	45	Battery	Type	Lead Acid			
			Capacity - 36V	AH	1430	1650	
	46			kWh	50.2	57.9	
			Capacity - 48V	AH	1100	1210	
	47			kWh	51.5	56.6	
			Weight - Min	lb	2800	3100	
			Weight - Max	lb	4000	4250	
			Size - Max	Length		32.94	36.38
				Width		38.69	
				Height		22.25	
48	Battery Floor Height	With Rollers / w/o Rollers	in	17.4 / 17.1			
Motors	49	Motors	Tractor Motor, dia	in	11.4		
	50		Lift Motor, dia	in	7.2		
51	Operating Pressure	For Attachments	psi	Up to 3000			

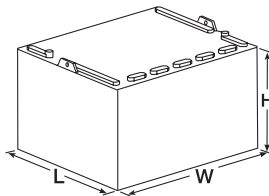

* Optional masts, attachments, longer load dimensions and higher lifting heights may result in derating of the capacity. Contact local dealer.

** Forward tilt restricted to 2° above this height.

† With maintenance-free batteries or batteries with a lid (flat top), consult factory.

†† Based on TT mast.

Mast Chart FC 4500-40/50/55			TL			TT							QUAD					
9	Lifting Height	in	126	138	150	188	206	216*	231*	246*	258*	276*	291*	240*	258*	276*	294*	312*
11	Free Lift Height†	in	5.6	5.6	5.6	32.2	38.2	44.2	50.2	56.2	62.2	68.2	74.2	31.8	39.8	43.8	49.8	55.8
14	Interlocked Fork Ht	in	78	78	78	66	72	78	84	90	96	102	108	76	82	88	94	100
17	Mast Collapsed Ht	in	83	89	95	83	89	95	101	107	113	119	125	83	89	95	101	107
18	Mast Extended Ht†	in	174	186	198	236	254	264	279	294	306	324	339	288	306	324	342	360

Mast Chart FC 4500-60			TL			TT					
9	Lifting Height	in	118	130	142	180	198	208*	223*	238*	250*
11	Free Lift Height†	in	5.9	5.9	5.9	32.2	38.2	44.2	50.2	56.2	62.2
14	Interlocked Fork Ht	in	78	78	78	66	72	78	84	90	96
17	Mast Collapsed Ht	in	83	89	95	83	89	95	101	107	113
18	Mast Extended Ht†	in	166	178	190	228	246	256	271	286	298

* Wide tread drive tires recommended. Refer to capacity charts.

† Includes load backrest.

FC 4500 Series

Technical Information

Standard Features

- Crown's Access 1 2 3® Comprehensive System Control
- Intrinsic Stability System™
 - Travel speed reduction when above mast staging
 - Forward tilt interlock above staging
 - Counterweight exceeds required standards
 - Ramp speed control
- Operator entry/exit
 - 18" step height
 - Large entry/exit "window"
 - Tubular overhead guard upright for easy hand hold
 - Contoured battery seat deck
 - Rounded floorboard edges
 - Tilt steering wheel and sculpted column
 - Large, uncluttered floorboard
- Operator compartment design features
 - Low cowl for fork and floor visibility
 - Wide visibility window between overhead guard and front pillars
 - Crown FlexSeat™ - fabric with hip restraint and anti-cinch seatbelt.
 - Infinite adjustment steering wheel column
 - Fingertip applied/released parking brake with tone alert

- Nylon control handles with tactile feedback
 - Natural position for forward/reverse selector
 - Rubber floor mat/rubber covered pedals
- AC traction system
 - Exclusive Crown power disc brake with regenerative motor plugging
 - Crown-manufactured lift motor
 - 36/48-volt system
 - Crown display
 - Battery discharge indicator with lift interrupt and re-key feature
 - Hour meters/travel distance/stop watch
 - Pin code access capable
 - Event code display with five (5) key navigation
 - Access 1 2 3 diagnostics
 - P1, P2, P3 Performance tuning
 - High visibility mast with in-line hose routing
 - Waterfall design overhead guard
 - Lift out or side removal battery access
 - Battery side retainer with interlock and fault identification
 - No tool lift out floorboards
 - 48" high load backrest
 - 350 amp battery connector

- Color-coded wiring
 - InfoPoint® System with Quick Reference Guide
 - Three-spool valve
 - O-ring face seal hydraulic fittings
 - Battery disconnect handle
 - Lift interrupt
- Optional Equipment**
- AC Hydraulics
 - Sideshifter
 - Freezer and corrosion conditioning
 - UL "EE" rating
 - InfoLink® Ready System
 - TL and quad mast styles
 - Polished and tapered forks
 - Fork lengths
 - Hydraulic valves for attachments
 - Quick disconnect hydraulic connectors
 - Attachment pressure regulator and gauge
 - Special forward tilt
 - Brush wear and motor over-temperature indicators for DC motors
 - Adjustable armrest
 - Steering spinner knob
 - Keyless on/off switch
 - Work lights
 - Storage tray with clipboard support
 - Suspension Seat - fabric or vinyl

- Tilt Position Assist
- Urethane covered control handles with tactile feedback (3" shorter)
- Back-up, brake and tail light
- Strobe lights
- Audible travel alarm
- Tow pin
- Automatic parking brake, (seat activated)
- Brake activated traction cutout
- Foot operated directional control
- Full battery side doors
- Battery compartment rollers
- Dock Performance Package
- Pos/Neg accessory cable
- Wide tread widths
- Load backrest heights
- Drive-in rack overhead guard
- Non-marking smooth or lug rubber tires
- Work Assist® Accessories
 - Clip pad and hook
 - Accessory clamp
 - Terminal mounting
 - Fire extinguisher
 - Operator fan
 - Work lights
 - Mirrors
- Battery spacer
- Crown FlexSeat - vinyl

Driveability

The FC 4500 benefits from Crown's design and engineering excellence. Numerous features improve operator comfort and productivity.

A low 18" step height first greets the operator. A low, streamlined battery cover helps the operator glide into the truck's seat. The overhead guard is shaped to open up the entry/exit window and its tubular design provides a comfortable hand grip location for a variety of operator heights. The compact tilt steer column and steer wheel further facilitate entry/exit. Tilt column is spring loaded to easily move up and away. Floorboard (625-sq in) is uncluttered and rubber covered to insulate the operator from vibration. Sculpted floorboard design promotes visibility to the drive tires, which can reduce product and pallet damage. Brake pedal effort is reduced. Pedal to pedal and floor to pedal relationships are refined for comfort.

Better visibility can be seen everywhere you look. A low cowl for fork and carriage visibility, a high visibility mast, a compact steer column, a sculpted floorboard and a "waterfall" overhead guard all contribute to superior visibility.

Control handles are crafted into the compartment and "fanned" for easy selection. They are urethane covered with tactile feedback for comfort and easy selection. Control actuation forces are minimal and responsive.

Finger applied/released parking brake with tone alert enhances operator entry/exit and naturally encourages its use. Battery disconnect is easy to reach and operate. Easy to actuate rocker-type switches are conveniently located to select optional work lights or fan. A large convex horn button is housed in the center of the wheel.

Crown Drive System

Crown has applied the latest generation AC drive system, enhanced with Access 1 2 3[®] technology. The demand for high efficiency systems that closely match customer torque requirements is met with this generation control system.

Drive motor is transverse-mounted high above the floor away from dirt and moisture. Heavy-duty triple reduction, all gear design operates in oil bath. Engineered for durability with reduced vibration and noise.

Crown's Access 1 2 3 technology provides optimum performance and control by offering a communication interface for both operators

and technicians, intelligent coordination of lift truck systems and simplified service with advanced diagnostics.

The Crown display is used for easy troubleshooting, access event history and set performance features. A distribution panel is conveniently located with all test points, control fuses and central wiring for easy troubleshooting.

Three modes of performance can be selected to accommodate operator experience or application requirements.

Crown Power Brake System

Service brakes are located in the wheel ends with a unique full circle power disc design. Hydraulic power is utilized to actuate a full circle rotor. This design reduces operator pedal effort and improves brake response. Brake service life is increased due to a large full circle friction pad. Access to the friction pads for inspection or replacement is direct and easy, reducing downtime for brake maintenance. Parking brake is activated by a push button located on the cowl to the right of the steer wheel column. Tone alert reminder is standard. Parking brake is located on the end of the motor shaft to take advantage of gear reduction. Optional seat activated automatic parking brake is available.

Steering

Fully hydrostatic system with equal area, double-acting cylinder provides equally responsive steering rate both ways (4.8 turns lock to lock). Rugged axle frame; forged spindle and connecting links eliminate the need for adjustment. One-piece forged spindle and kingpin in tapered roller bearings for improved life and serviceability. Spherical bearings with tapered pins in connecting links eliminate any play in linkage. All bearing locations are sealed to exclude contaminants and are equipped with lubrication fittings for ease of service. Axle articulates in rubber isolation bushing to improve truck handling and ride.

Crown Manufactured Mast Assembly

Large, rugged mast trunnion mount on drive axle and extra heavy tilt cylinders with self-aligning bushings secure mast.

High visibility mast features nested-rail design with lift cylinders positioned behind the rails. Heavy-duty mast is engineered to provide smooth reliable operation. Large hydraulic hose reeves and hose placement are engineered to reduce hose wear and increase hose life. Hose routing places hoses in-line versus side-by-side to reduce visual interference. Large lift chains are used for long reliable service life. Large diameter lift cylinders provide smooth operation.

Class II and III fork carriages are available. Optional TL and quad mast is available.

Hydraulics

Premium hydraulic function control valve provides precise metering of lift, tilt and accessory functions. Compensating section in the valve provides repeatable function speed regardless of load condition. Hydraulic lever actuation is minimal, reducing stress. Compensating section also improves overall system efficiency.

Tilt compensator prevents tilt from lunging or speeding up when doing simultaneous functions.

Crown lift/tilt interlock system provides extended forward tilt at low fork heights, reduced forward tilt at elevated heights to improve truck stability when forks are elevated.

The control valves' modular design allows easy addition of accessory functions. Maximum lowering speed is limited by pressure compensating flow control valve and velocity fuses. Integrated hydraulic cylinder cushions soften mast staging.

All lift cylinder rams are plated and retract into the hydraulic oil for additional corrosion protection when forks are lowered.

The steel oil reservoir is integral to the frame which helps to dissipate hydraulic oil heat. This clean, leak-free design includes suction strainer with separate, easily accessible fill port and dipstick with filtered breathers. Oil is returned through a replaceable spin-on type oil filter.

Batteries

Battery deck lid releases easily to expose battery for lift out or side battery removal. Optional battery rollers for use with mechanized extraction equipment. A low battery side retainer is standard. Full battery side doors are optional.

Other Options

- 1. Audible travel alarm
- 2. Flashing lights

Safety considerations and dangers associated with audible travel alarms and flashing lights include:

- Multiple alarms and/or lights can cause confusion.
- Workers ignore the alarms and/or lights after day-in and day-out exposure.
- Operator may transfer the responsibility for "looking out" to the pedestrians.
- Annoys operators and pedestrians.

Other Options Available

Contact your local Crown dealer.

Dimensions and performance data given may vary due to manufacturing tolerances. Performance is based on an average size vehicle and is affected by weight, condition of truck, how it is equipped and the conditions of the operating area. Crown products and specifications are subject to change without notice.



You can count on Crown to build lift trucks designed for safe operation, but that's only part of the safety equation. Crown encourages safe operating practices through ongoing operator training, safety-focused supervision, maintenance and a safe working environment. Go to crown.com and view our safety section to learn more.

Crown Equipment Corporation

New Bremen, Ohio 45869 USA
Tel 419-629-2311
Fax 419-629-3796
 crown.com

Because Crown is continually improving its products, specifications are subject to change without notice.

Crown, the Crown logo, the color beige, the Momentum symbol, Access 1 2 3, InfoPoint, Intrinsic Stability System, FlexSeat, InfoLink and Work Assist are trademarks of Crown Equipment Corporation.

Copyright 2007-2010 Crown Equipment Corporation SF14837 Rev. 9/10 Printed in U.S.A.